

James R. Williams, Jr.
Shareholder
(305) 376-6008
jameswilliams@gunster.com

March 24, 2026

Via Electronic Submission

Mr. Alexander Magrisso
Planning & Zoning Director
8401 NW 53 Terrace, 2nd Floor
Doral, Florida 33166

Re: Amended and Restated Letter of Intent / Amendment to the Official Zoning Map to Include Portions of Miami International Mall within the “Mall Mixed Use” Zoning District (the “Application”) / Greystar Development East, LLC / Property Generally Located at 1625 NW 107 Avenue and 1603 NW 107 Avenue / Folio Numbers 35-3032-008-0050, 35-3032-008-0140, and Portion of 35-3032-008-0010

Dear Mr. Magrisso:

This Amended and Restated Letter of Intent is submitted on behalf of Greystar Development East, LLC (the “**Applicant**”), for its application for a public hearing in connection with its request to amend the Official Zoning Map of the City of Doral (the “**City**”) to designate approximately 25.612 acres within Miami International Mall (the “**Mall**” or “**Miami International Mall**”) as part of the “Mall Mixed Use” zoning district, specifically on those parcels identified by Miami-Dade County Tax Folio Numbers 35-3032-008-0050, 35-3032-008-0140, and a portion of 35-3032-008-0010 (the “**Property**”). For reference, an aerial exhibit outlining the Property’s general boundaries in green is included below.

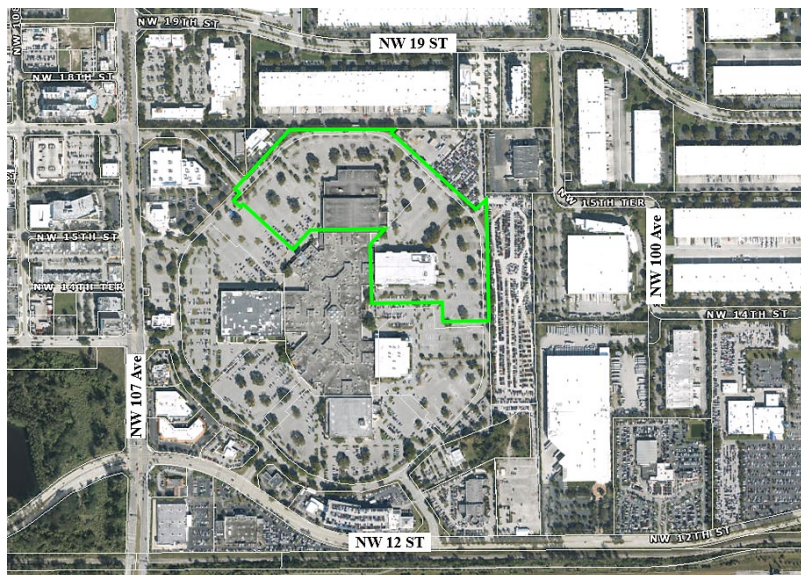

Request Overview. The proposed inclusion of the Property within the “Mall Mixed Use” (MMU) district will enable the horizontal integration of a high-quality multifamily residential community within an established regional shopping center. This integration is consistent with the City’s Comprehensive Plan and reflects the City’s evolving land-use patterns toward more vibrant, sustainable, and mixed-use environments.

The Property comprises portions of the Miami International Mall (the “Mall”) previously occupied by former big-box department stores and the adjacent surface parking areas. The Mall is located at the northeast corner of NW 107 Avenue and NW 12 Street, with direct access to major transportation corridors, public transit options, and full urban services. The Applicant proposes to introduce residential uses as a complementary component to the existing Mall, fostering a more walkable, activated, and integrated mixed-use setting. The residential development will support and enhance the Mall’s ongoing reinvestment and activation initiatives, including the introduction of the Elev8 Fun family entertainment anchor, and will strengthen the Mall’s long-term economic viability and competitiveness as a regional destination.

As of the date of this letter, the Applicant has also filed the following nine (9) concurrent application requests:

1. A Comprehensive Plan Text Amendment to create the “Mall Mixed Use” designation to permit residential development as applied to the proposed “Mall Mixed Use” Zoning District.
2. A Future Land Use Map Amendment to redesignate the Property from “Business” to “Mall Mixed Use.”
3. A Land Development Code Amendment to create the Mall Mixed Use District.
4. Site Plan Approval application to allow the development a multifamily residential project on the west ± 7.327 acres (319,162 square feet) of that certain parcel of land located at 1625 NW 107 Avenue and identified by Miami-Dade County Tax Folio Number 30-3032-008-0050 (“**Residential Site No. 1**” or “**Site 1**”).
5. Site Plan Approval application to allow the development a multifamily residential project on the east ± 5.66 acres (246,788 square feet) of that certain parcel of land located at 1625 NW 107 Avenue and identified by Miami-Dade County Tax Folio Number 30-3032-008-0050 (“**Residential Site No. 2**” or “**Site 2**”).
6. A Modification to the Miami International Mall Consolidated Development of Regional Impact (“Miami International Mall Consolidated DRI”) Development Order to permit residential development within Miami International Mall.
7. The Administrative Release of a Declaration of Use recorded in Official Records Book 17735, Page 3022, which restricted the use of a portion of the Property to a limited automobile service center.

8. A Partial Release of the Declaration of Restrictions recorded in Official Records Book 10619, Page 1984 of the Public Records of Miami-Dade County, Florida.
9. A Modification of the Declaration of Restrictive Covenants recorded in Official Records Book 11212, Page 1613 of the Public Records of Miami-Dade County, Florida.

Project Background. The Property comprises portions of the Mall previously occupied by former big-box department stores and the adjacent surface parking areas. The Project represents a once-in-a-generation opportunity to reimagine underutilized retail space at Miami International Mall as a vibrant, design-forward residential community, one that breathes new life into a beloved South Florida landmark while delivering the kind of activated, mixed-use destination that modern urban communities demand. Greystar, one of the world's leading multifamily developers, brings to this Project a proven track record of transformative residential development and a genuine commitment to quality, sustainability, and community integration.

Miami International Mall has served as a cornerstone of the Doral community for decades. Yet like many regional malls across the country, it now faces the structural shifts that have transformed brick-and-mortar retail. Rather than resist these forces, the Applicant embraces them, proposing a forward-looking, mixed-use redevelopment that honors the mall's legacy while securing its long-term relevance and vitality.

The Project's overall introduction of a maximum of 896 new residences at a location with unmatched connectivity and access to employment, retail, dining, and entertainment, all within the City of Doral, one of South Florida's most desirable and fastest-growing communities. The Project delivers the kind of high-quality, professionally managed rental housing that Doral residents and workers are actively seeking, helping to address a regional need while generating meaningful economic activity, employment, and tax base for the City.

Amendment to the Official Zoning Map. The Applicant proposes an amendment to the Official Zoning Map to include portions of Miami International Mall within the Mall Mixed Use (MMU) zoning district. The MMU aligns with these regional dynamics and the City's smart-growth principles by facilitating efficient infill redevelopment on existing greyfield sites, reusing paved areas and vacant anchor pads rather than consuming undeveloped land. As the City considers updates to its Comprehensive Plan and LDC, it is essential that these documents reflect evolving market conditions and regional land-use patterns. Creation of the MMU district will help promote balanced development, revitalize aging commercial centers, and introduce new active uses that support economic resiliency and long-term community vitality.

Analysis of Review Requirements. In accordance with Section 53-213 of the City's Land Development Code, the Zoning Map Amendment shall be reviewed and analyzed for consistency with the City's Comprehensive Plan as follows:

- a) Whether justified by changed or changing conditions.

The requested amendment is clearly justified by changed and changing conditions affecting both the Property and the broader regional retail marketplace.

Traditional department-store anchors have declined nationwide, including at Miami International Mall, creating opportunities for adaptive reuse of large-format retail spaces. The Mall is presently transitioning toward experiential and entertainment-based tenancy, most notably the forthcoming Elev8 Fun family entertainment center occupying approximately 110,000 square feet of the former Kohl's building. This transition reflects a broader industry shift from conventional retail toward experience-driven destinations that combine entertainment, dining, and residential uses.

Comparable regional malls throughout South Florida have undergone similar transformations. For example, The Shops at Sunset Place in South Miami and Southland Mall, now redeveloping as Southplace City Center, have incorporated substantial residential components to revitalize underutilized retail properties and create integrated mixed-use environments. These examples illustrate a regional evolution in which dormant or underperforming retail acreage is repurposed to accommodate housing and complementary uses.

The proposed MMU zoning district designation responds directly to these changing economic conditions by enabling the adaptive reuse of the Mall property and aligning the City's zoning framework with contemporary land-use patterns. Approval of the amendment will facilitate the continued evolution of the Mall as a modern, diversified activity center.

b) Whether adequate sites already exist for the proposed district uses.

Although residentially zoned parcels exist elsewhere in the City, no comparable site offers the combination of attributes present at the Mall:

- First, the Property benefits from regional accessibility and existing infrastructure, including established roadway access, utilities, and transit proximity, thereby accommodating new residential development without requiring substantial new public investment; and
- Second, the Property is located within an established regional commercial center that provides immediate access to employment opportunities, retail services, dining, and entertainment amenities. By introducing residential uses within the existing Mall environment, the proposed district promotes a live-work-play development pattern in which residents can conveniently access daily needs by walking or biking, thereby reducing vehicle trips and improving overall land-use efficiency.

- Third, the request encourages the redevelopment of greyfield land, utilizing existing paved areas and underutilized anchor pads rather than consuming undeveloped land. This approach advances the City’s smart-growth objectives by directing new residential development to already urbanized areas where infrastructure capacity already exists.

For these reasons, the “Mall Mixed Use” zoning district encourages efficient infill on greyfield land, reusing paved areas and vacant anchor pads rather than consuming new land, thus advancing the City’s smart-growth principles. The Mall’s location and infrastructure make it uniquely suited to accommodate new residential development in a manner that reinforces the vitality of existing commercial assets.

- c) Whether specific requirements of this Land Development Code are adequate to ensure compatibility with adjoining properties as required by the comprehensive plan.

The proposed amendments to the City’s Land Development Code establishing the “Mall Mixed Use” (MMU) zoning district, which are concurrently submitted with this Application, include comprehensive development standards designed to ensure compatibility between new residential uses and surrounding properties.

These standards include regulations governing building height, setbacks, landscaping, buffering, open space, and parking. Together, these requirements will ensure that new residential buildings are appropriately integrated within the existing Mall environment while maintaining compatibility with adjacent properties.

In addition, the Mall’s existing internal ring road and expansive perimeter setbacks create substantial physical separation between the proposed residential buildings and surrounding property boundaries. This condition provides buffering and spatial separation that exceeds what is typically available on conventional infill development sites.

Finally, the application of the MMU district will not eliminate the City’s oversight of future development. Rather, the City will retain full authority to review and approve individual site plans and architectural designs pursuant to the City’s Land Development Code procedures. This review process will ensure that all proposed multifamily development satisfies the City’s aesthetic, functional, and compatibility standards.

The proposed comprehensive standards to the City’s Land Development Code establishing the “Mall Mixed Use” (MMU) zoning district, concurrently filed with this Application, will ensure the seamless integration of residential uses within the existing Mall and promote compatibility with surrounding properties. These include controls on building height, setbacks, landscaping, buffering, open space, and parking requirements. Additionally, the Mall’s internal ring road and expansive perimeter setbacks provide a substantial physical separation between proposed residential buildings and external Property lines, ensuring compatibility far exceeding that of typical infill sites.

By applying the MMU zoning district to the Property, the City will retain full site plan and design-review approval authority under the established City Land Development Code procedures, ensuring that each proposed multifamily development meets aesthetic and functional compatibility standards consistent with the Comprehensive Plan.

Consistency with the Comprehensive Plan. The Application maintains internal consistency within the Comprehensive Plan and advances its adopted goals, objectives, and policies. Specifically, the Project furthers the following Comprehensive Plan policies:

***Policy 1.1.3:** Where appropriate, place higher densities in close proximity to transit stops. By January 2018, complete a study with recommended actions of land use and zoning densities near transit access points in Doral measuring them against a minimum transit viability density standard of 7 units per acre.*

The Project directly advances the City's mobility and sustainability objectives by locating new residential density within walking distance of existing transit service. By introducing a meaningful number of residential units at this location, the Project helps support the City's goal of achieving transit-supportive densities that meet or exceed the minimum viability threshold of 7 units per acre. This strategic infill pattern not only reduces reliance on single-occupancy vehicles but also strengthens ridership potential for future transit expansions envisioned in the Comprehensive Plan. The Project therefore aligns with Policy 1.1.3 by reinforcing Doral's emerging multimodal urban fabric and placing households exactly where transit can serve them most efficiently.

***Policy 1.1.4:** Search for evolving opportunities in the Future Land Use Element (FLUE) and LDC for additional cluster residential development and energy-efficient, multi-story homes on smaller lots.*

The Project transforms an underutilized commercial property into a more sustainable and efficient land use consistent with the City's long-term planning directives. By incorporating multi-story residential buildings with modern, energy-efficient systems, the Project demonstrates the type of forward-looking housing model envisioned by this policy. The site's compact development structure allows for a more thoughtful use of land, enabling additional green space and reduced impervious surface. This redevelopment represents exactly the kind of opportunity the Comprehensive Plan encourages—leveraging infill sites to deliver high-quality, energy-efficient housing in a clustered, space-efficient configuration.

***Policy 1.4.4:** Look for opportunities to preserve and expand open green space in the City. Revisit current standards for open space, parking, and local roadway dimensions with an eye toward reducing impervious area. Incentives for multi-story, cluster housing and structured parking should also be explored. Also, consider reducing*

parking space requirements for private developments within ½ mile of a transit stop.

The Project addresses the City’s environmental and urban design objectives by replacing predominantly paved, low-yield commercial land with a thoughtfully planned residential development that integrates meaningful open green space. By utilizing multi-story residential forms and exploring reduced parking needs due to proximity to transit, the Project significantly decreases the site’s impervious footprint. This development approach directly supports Policy 1.4.4 by demonstrating how higher-density, vertical development can increase on-site green areas while promoting a more walkable, transit-supportive environment. The Project exemplifies the City’s vision of using redevelopment as a tool to restore green space and reduce heat-island effects.

***Policy 2.1.13:** Discourage land use patterns indicative of urban sprawl in the Future Land Use Map and any amendment applications by dictating compact development, mixed-use where appropriate, and efficient use of public facility capacity and resources, while protecting single-family neighborhoods.*

By shifting an exclusively commercial parcel toward a mixed-use, compact residential pattern, the Project directly counters sprawl-related land consumption and advances the City’s goal of promoting more efficient use of existing urban areas. The site is already serviced by infrastructure and proximate to employment, schools, and transit routes. Introducing residential uses here aligns with Policy 2.1.13 by strengthening the City’s internal land use balance, reducing commute distances, and promoting infill rather than outward expansion. This redevelopment approach supports the City’s long-term strategy of cultivating walkable, mixed-use districts that optimize land resources and decrease development pressure on peripheral areas.

***Policy 4.1.1:** Through the City’s adopted Future Land Use Map and land use designations, promote a mix of residential land use categories and densities throughout the City.*

The Project contributes directly to the City’s objective of diversifying residential opportunities by introducing a mixed-use land use category in an area currently restricted to commercial activity. This broadens the variety of housing types available to residents while enhancing the balance between residential and employment uses within the community. The Project’s proposed density and housing typology complement the surrounding urban context and advance the City’s intent to distribute residential uses more strategically across Doral’s urban landscape. In doing so, the Project supports a healthier, more sustainable mix of land uses citywide.

***Policy 4.1.8:** Increase the City’s residential potential within designated areas such as the DMU and CMU land use categories to promote mixed use development.*

The Project reinforces the City’s mixed-use planning framework by increasing residential capacity within a designated mixed-use area (i.e., the proposed MMU). Consistent with Policy

4.1.8, the application strengthens the vitality of the area by adding housing that will support nearby commercial, civic, and neighborhood-serving uses. By incorporating residential development into an area already conceptually structured for mixed use, the Project activates the district with a built-in resident base, creating a more complete, self-sustaining neighborhood ecosystem. This directly fulfills the Comprehensive Plan's goal of leveraging mixed-use districts to expand housing opportunities while enhancing walkability and reducing transportation impacts.

Conclusion. The proposed Zoning Map Amendment to include the Property within the Mall Mixed Use (MMU) zoning district satisfies all three criteria outlined in Section 53-213 of the City's Land Development Code. This request is justified by demonstrable and sustained changes in retail market conditions, the strategic availability of an infill site supported by existing municipal infrastructure, and the inclusion of development standards designed to ensure compatibility with adjacent properties and surrounding land uses.

The amendment is fully consistent with the goals, objectives, and policies of the City's Comprehensive Plan and appropriately responds to evolving market and policy trends that promote the adaptive reuse and reinvestment of established commercial centers.

For these reasons, the Applicant respectfully requests approval of the inclusion of the Property within the MMU zoning district to enable the thoughtful redevelopment of Miami International Mall as a vibrant, sustainable, and economically resilient mixed-use destination.

Based on the foregoing, we respectfully request your favorable review and recommendation. Thank you in advance for your considerate attention to this application. If you should have any questions or require any additional information, please do not hesitate to contact me at (305) 376-6008.

Respectfully submitted,

GUNSTER



James R. Williams Jr., Esq.

Cc: Catherine M. Carbonell, Esq.
Alberto J. Torres, MBA, MM



8401 NW 53RD Terrace, Second Floor, Doral, Florida 33166 Tel. (305) 593-6630 Facsimile: (305) 593-6768 Website: cityofdoral.com

PUBLIC HEARING/ ADMINISTRATIVE REVIEW APPLICATION **PLANNING AND ZONING DEPARTMENT**

Please check one:

- CITY COUNCIL
- ADMINISTRATIVE REVIEW

OFFICIAL USE ONLY
 Application No.: land-2511-0033
 Date Received:

REVISED
 10:10 am, Mar 27, 2026

INSTRUCTIONS

This application, with all supplemental data and information, must be completed in accordance with the specific instructions in this application. Applications and all supplemental information must be filed no later than 60 days prior to the regular public hearing date.

APPLICATION

Please indicate which type of application you are submitting by checking one category below:

- Change in Zoning District
- Variance
- Appeal of Decision
- Conditional Use
- Plat
- Entry Feature
- Site Plan
- Other Amendment to Official Zoning Map

IMPORTANT: THE APPLICANT, OR REPRESENTATIVE, MUST BE PRESENT AT THE HEARING TO PRESENT THE PROPOSAL.

Please print or type

Name of Applicant, agent or tenant (with owner's affidavit)		
James R. Williams Jr., Esq. on behalf of Greystar Development East, LLC		
Mailing Address	City, State, Zip	Telephone 305-376-6008
c/o James R. Williams Jr., Esq. Gunster, Yoakley, & Stewart, P.A. 600 Brickell Avenue, Suite 3500	Miami, Florida 33131	Fax Email: c/o jameswilliams@gunster.com ccarbonell@gunster.com
Name of Owner		
Please see Exhibit A		
Mailing Address	City, State, Zip	Telephone
		Fax Email:

PROPERTY INFORMATION

A. LEGAL DESCRIPTION. (If subdivided – lot, block, complete name of subdivision, plat book and page numbers). If metes and bounds description – Complete description, including section, township and range).

Folio Number(s) 35-3032-008-0050; 35-3032-008-0140; and a portion of 35-3032-008-0010

Address Reference Addresses: 1625 NW 107 Avenue and 1603 NW 107 Avenue

Lot(s) _____ Block _____ Section _____ Plat Book No. 117 Page No. 84

FINISHED FLOOR ELEVATION (If applicable): _____ FLOOD ZONE: _____

B. ADDRESS (If number has been assigned) _____

C. SIZE OF PROPERTY _____ ft. X _____ ft. = +/- 1,115,703 sq. ft.; +/- 25.612 acre(s)
Width Depth

D. Provide legal description or address of any property held by the owner which is contiguous to that which is the subject matter of this application.

E. DATE SUBJECT PROPERTY WAS ACQUIRED Please see Exhibit A

APPLICANT'S REQUEST:

Specify in full the request. (Use a separate sheet of paper if necessary.)

Amendment to Official Zoning Map including the property within the proposed "Mall Mixed Use" District.

LETTER OF INTENT

Explain purpose of application, benefit(s) in the change and reasons why this application should be approved. Specify the exact nature of the use or operation applied for, together with any pertinent technical data, which will clarify the proposal. (Use a separate sheet of paper if necessary.)

Please see the letter of intent included as part of this application.

Is this application the result of a Notice of Violation or deviation from approved plans? Yes No

Are there any existing structures on the property? Yes No

If so, what type? (CBS, Frame, Frame-Stucco, Wood, Other) CBS

Any applications that involve an existing building must provide copy of the approved plans, plat, site plan approval or any prior zoning history. Plans that are not filed with this application will not be considered by the City of Doral.

All data and exhibits submitted in connection with this application become a PERMANENT PART OF THE PUBLIC RECORDS OF THE CITY OF DORAL.

The following enclosures where applicable MUST BE ATTACHED to complete the application:

- A. **SURVEY OF PROPERTY:** For vacant or improved property. Must be no more than one year old and sealed by a registered land surveyor. The Building and Planning Department may require a more recent survey if a site visit indicates any discrepancies. Survey must include, where applicable, lot lines, all structures, walls, fences, landscaping, and all physical improvements. All existing trees must be shown.
- B. **SITE DEVELOPMENT PLAN:** Where applicable, plans shall show location and elevations of existing and proposed buildings, proposed additions, alterations and use of each; all dimensions of buildings and space between buildings; setbacks from property lines; proposed and existing off-street parking showing lined spaces, driveways, handicap spaces, compact spaces; a landscape plan that complies with the City of Doral Landscape Ordinance showing location of existing and proposed vegetation, landscaping (i.e. trees and hedges), number, height and species type. The plan shall also show wall and fence height, location and material. Prior ASPR or Site Plan Approval Resolution and plans must be submitted.
- C. **LETTER OF INTENT:** A letter of intent must be filed explaining in detail the history of the property, prior approvals and the extent of the proposed project. Show how code criterion is met. Signature and address must be shown.
- D. **OTHER GOVERNMENTS/AGENCIES ENDORSEMENTS:** All applicable DERM, Miami-Dade Fire Department, or the Miami-Dade Water and Sewer Department's endorsement must be submitted.
- E. **OWNER'S AFFIDAVIT:** Owner's affidavit allowing the filing of an application is required on all applications where the applicant is not the owner of the property under consideration; same form allows posting of property.
- F. **TRAFFIC STUDY:** A detailed traffic analysis considering the impacts of the proposed development on current level-of-service (LOS) standards in abutting (or nearby) roads and intersections.

NOTE: SURVEYS, SITE DEVELOPMENT PLANS, LANDSCAPE PLANS MUST BE SUBMITTED AT STANDARD PLAN SIZE. AN APPLICATION WILL NOT BE CONSIDERED COMPLETE UNLESS THE APPLICATION AND SUPPORTING DOCUMENTATION (FRONT AND BACK), APPROPRIATE PLAN DRAWINGS AND SURVEYS ARE SUBMITTED.

In support of this request, I submit the following additional items, which are attached hereto and made a part of this application:

- 35 MM Photo(s) (Mounted 8 1/2 x 11)
- Letters from Area Residents
- Other _____

Please check only one of the following options:

- FOR CITY COUNCIL PURPOSES

I/We understand that additional public hearings may be required and any interested person may discuss the application with City staff to the same extent as the applicant. The application may change during the hearing process and additional public notices may affect the schedule of the hearings. If my/our appeal is denied, I/we must file an appeal to the Circuit Court within 30 days of the meeting.

10/7/2025
Date

Lewis Stoneburner, Vice President of Greystar Development East, LLC

I/We EWE RETAIL II LTD, a Florida limited partnership as Owner (s) of Lot (s) a portion of Tract A

Block _____ Section _____ PB/PG 117/84

of property which is located at 1625 NW 107 Avenue, Miami, Florida
desire to file an application for review before the City, I/We do understand and agree as follows:

1. That the application for public hearing will not be heard unless the applicant is present at the hearing.
2. The property will be posted with a sign, which must not be removed until after the public hearing, at which time the City staff will remove the sign. The applicant will be responsible for advertising the application and sending the mail out per the notification requirements of the City Code.
3. That the requirements of the Municipal Code, Miami-Dade County Ordinances, the Florida Building Code (FBC), and other government agencies may affect the scheduling and ability to obtain/issue a permit for the proposal.
4. That the only exceptions to the City's Land Development Code (LDC) are those that have been specified in the written application (via variance application) and any other code or plan issues will be corrected by modifying the plans to comply with the respective codes and ordinances of the City of Doral or Miami-Dade County ordinances.
5. That the applicant will be responsible for complying with all the conditions and restrictions imposed by the City Council or City Staff in connection with the request and will take the necessary steps to make the request effective if approved by the City Council or City Staff.
6. That it is the responsibility of the applicant to submit a complete application with all of the documents necessary for the City Council or City Staff to consider the applicant's request.
7. That the applicant is responsible for timely submission and accuracy of all items requested on the application. Any information submitted less than 45 days prior to a public hearing will result in being postponed to the next available hearing date. Legislative items must have all requested items submitted 30 days prior to hearing.
8. That the applicant is responsible for any additional fees which include but are not limited to mailing notices to surrounding property owners, advertising, outside consultant reviews, legal fees, surveys, and technical reports.

I/We as the owners of the subject property (check one):

do hereby authorize James Williams Jr., Esq. and Gunster, Yoakley, Stewart, P.A. on behalf of Greystar Development East, LLC as the applicant to act on my/our behalf as the applicant.

will on my/our own behalf act as applicant(s), and make application in connection with this request for a public hearing administrative review before the City Council or City Staff.

Owner's Name EWE RETAIL II LTD, a Florida limited partnership Signature [Signature] Date 10-15-25
Name Edward J. Easton Title Manager

Notary to Owner: The foregoing instrument was acknowledged before me by means of physical presence or online notarization this 15 day of Oct, 2025 by Edward J. Easton as mgr. for EWE RETAIL II LTD, who is personally known to me or provided identification:

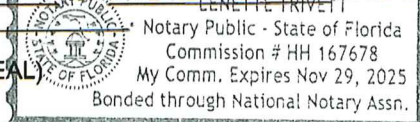
(NOTARY SEAL) 

Signature of Notary: [Signature]
Name of Notary: Lenette Trivett

Applicant's Name Greystar Development East, LLC, a Delaware limited liability company Signature [Signature] Date 10/7/2025
Lewis Stoneburner, Vice President

Notary to Applicant: The foregoing instrument was acknowledged before me by means of physical presence or online notarization this 7th day of October, 2025 by Lewis Stoneburner as Vice President for Greystar Development East, LLC, who is personally known to me or provided identification:

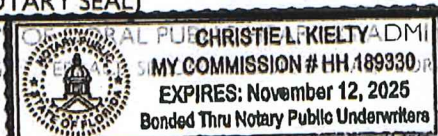
(NOTARY SEAL) 

Signature of Notary: [Signature]
Name of Notary: Christie Kielty

I/We JCP INTERNATIONAL I LLC, a Florida limited liability company as Owner (s) of Lot (s) a portion of Tract A

Block _____ Section _____ PB/PG 117/84

of property which is located at 1603 NW 107 Avenue, Miami, Florida
desire to file an application for review before the City, I/We do understand and agree as follows:

1. That the application for public hearing will not be heard unless the applicant is present at the hearing.
2. The property will be posted with a sign, which must not be removed until after the public hearing, at which time the City staff will remove the sign. The applicant will be responsible for advertising the application and sending the mail out per the notification requirements of the City Code.
3. That the requirements of the Municipal Code, Miami-Dade County Ordinances, the Florida Building Code (FBC), and other government agencies may affect the scheduling and ability to obtain/issue a permit for the proposal.
4. That the only exceptions to the City's Land Development Code (LDC) are those that have been specified in the written application (via variance application) and any other code or plan issues will be corrected by modifying the plans to comply with the respective codes and ordinances of the City of Doral or Miami-Dade County ordinances.
5. That the applicant will be responsible for complying with all the conditions and restrictions imposed by the City Council or City Staff in connection with the request and will take the necessary steps to make the request effective if approved by the City Council or City Staff.
6. That it is the responsibility of the applicant to submit a complete application with all of the documents necessary for the City Council or City Staff to consider the applicant's request.
7. That the applicant is responsible for timely submission and accuracy of all items requested on the application. Any information submitted less than 45 days prior to a public hearing will result in being postponed to the next available hearing date. Legislative items must have all requested items submitted 30 days prior to hearing.
8. That the applicant is responsible for any additional fees which include but are not limited to mailing notices to surrounding property owners, advertising, outside consultant reviews, legal fees, surveys, and technical reports.

I/We as the owners of the subject property (check one):

do hereby authorize James Williams Jr., Esq. and Gunster, Yoakley, Stewart, P.A. on behalf of Greystar Development East, LLC as the applicant to act on my/our behalf as the applicant.

will on my/our own behalf act as applicant(s), and make application in connection with this request for a public hearing administrative review before the City Council or City Staff.

Owner's Name JCP INTERNATIONAL I LLC, a Florida liability company Signature [Signature] Date 10-15-25
Name Edward J. Easton Title Manager

Notary to Owner: The foregoing instrument was acknowledged before me by means of physical presence or online notarization this 15 day of OCT., 2025 by Edward J. Easton as Mgr. for JCP INTERNATIONAL I LLC, who is personally known to me or provided identification:

(NOTARY SEAL)  Signature of Notary: [Signature]
Name of Notary: Lenette Trivett

Applicant's Name Greystar Development East, LLC a Delaware limited liability company Signature [Signature] Date 10/7/2025
Lewis Stoneburner, Vice President

Notary to Applicant: The foregoing instrument was acknowledged before me by means of physical presence or online notarization this 7 day of October, 2025 by Lewis Stoneburner as Vice President for Greystar Development East, LLC, who is personally known to me or provided identification:

(NOTARY SEAL) Signature of Notary: [Signature]
Name of Notary: Christie Kielty

PUBLIC HEARING ADMINISTRATIVE REVIEW APPLICATION

OWNER AFFIDAVIT

I/We West Dade County Associates, a Florida general partnership as Owner (s) of Lot (s) a portion of Tract A

Block _____ Section _____ PB/PG 117/84

of property which is located at the northeast corner of Tract A of Plat Book 117, Page 84, generally desire to file an application for review before the City, I/We do understand and agree as follows:

1. That the application for public hearing will not be heard unless the applicant is present at the hearing.
2. The property will be posted with a sign, which must not be removed until after the public hearing, at which time the City staff will remove the sign. The applicant will be responsible for advertising the application and sending the mail out per the notification requirements of the City Code.
3. That the requirements of the Municipal Code, Miami-Dade County Ordinances, the Florida Building Code (FBC), and other government agencies may affect the scheduling and ability to obtain/issue a permit for the proposal.
4. That the only exceptions to the City's Land Development Code (LDC) are those that have been specified in the written application (via variance application) and any other code or plan issues will be corrected by modifying the plans to comply with the respective codes and ordinances of the City of Doral or Miami-Dade County ordinances.
5. That the applicant will be responsible for complying with all the conditions and restrictions imposed by the City Council or City Staff in connection with the request and will take the necessary steps to make the request effective if approved by the City Council or City Staff.
6. That it is the responsibility of the applicant to submit a complete application with all of the documents necessary for the City Council or City Staff to consider the applicant's request.
7. That the applicant is responsible for timely submission and accuracy of all items requested on the application. Any information submitted less than 45 days prior to a public hearing will result in being postponed to the next available hearing date. Legislative items must have all requested items submitted 30 days prior to hearing.
8. That the applicant is responsible for any additional fees which include but are not limited to mailing notices to surrounding property owners, advertising, outside consultant reviews, legal fees, surveys, and technical reports.

I/We as the owners of the subject property (check one):

do hereby authorize James Williams Jr., Esq. and Gunster, Yoakley, Stewart, P.A. on behalf of Greystar Development East, LLC as the applicant to act on my/our behalf as the applicant.

will on my/our own behalf act as applicant(s), and make application in connection with this request for a public hearing administrative review before the City Council or City Staff.

Owner's Name West Dade County Associates, Signature [Signature] Date 3/16/26
a Florida general partnership Name John Bulli Title Chief Administrative Officer

Notary to Owner: The foregoing instrument was acknowledged before me by means of physical presence or online notarization this 14th day of March, 2025, by John Bulli as CEO for West Dade County Associates, who is personally known to me or provided identification: _____

(NOTARY SEAL) Jan L. Locke Notary Public, State of Indiana
Signature of Notary: [Signature]
Name of Notary: Jan L. Locke
Commission Number NP0767149
My Commission Expires November 16, 2033

Applicant's Name Greystar Development East, LLC, Signature [Signature] Date 10/7/2025
a Delaware limited liability company Lewis Stoneburner, Vice President

Notary to Applicant: The foregoing instrument was acknowledged before me by means of physical presence or online notarization this 7 day of October, 2025, by Lewis Stoneburner as Vice President for Greystar Development East, LLC, who is personally known to me or provided identification: _____

(NOTARY SEAL) Signature of Notary: [Signature]
Name of Notary: Christie Kielty

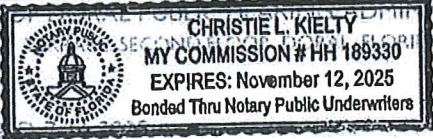

City Code Sec. 2-279, Charges for consulting services established.

(a)The city manager or his/her designee, in the review of any application, may refer any such application presented to it to such engineering, planning, legal, technical, or environmental consultant or professionals employed by the city as the manager shall deem reasonably necessary to enable him to review such application as required by law. Charges made by such consultant shall be in accord with the charges customarily made for such services in the county, and pursuant to an existing contractual agreement by and between the city and such consultant. Charges made by the city shall be in accord with the hourly rates charged by such consultants or hourly rates of employed professionals and shall be paid on submission of a city voucher.(b)The applicant shall reimburse the city for the cost of such consultant or employed professional services upon submission of a copy of the voucher, within 30 days of submission of a copy of the voucher and as a condition of the zoning resolution. These fees are in addition to any and all other fees required by other law, rule, or regulation of this Code. (Ordinance No. 04-07)

I, EWE RETAIL II LTD, a Florida limited partnership (Property Owner), hereby acknowledge and consent to the payment of all applicable fees as it relates to the application and request for the review and processing of the requested Administrative Hearing, Public Hearing, or legal instrument. Fees shall include, but are not limited to review by city staff, city contractors, agents or consultants, advertisement(s), recordings, mailings, and any additional costs related to the submitted application.

Affidavit to be executed by property owner. All right and entitlements run with the property.

Owner's Name EWE RETAIL II LTD, a Florida limited partnership Signature [Signature] Date 10-15-25
Name Edward J. Easton
Title Manager

Notary to Owner: The foregoing instrument was acknowledged before me by means of physical presence or online notarization this 15 day of OCT, 2025 by Edward J. Easton as Mgr. for EWE RETAIL II LTD, who is personally known to me or provided identification:

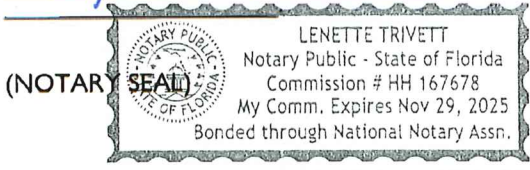

Signature of Notary: [Signature]
Name of Notary: Lenette Trivett

Applicant's Name Greystar Development East, LLC, a Delaware limited liability company Signature [Signature] Date 10/7/2025
Lewis Stoneburner, Vice President

Notary to Applicant: The foregoing instrument was acknowledged before me by means of physical presence or online notarization this 7 day of October, 2025 by Lewis Stoneburner as Vice President for Greystar Development East, LLC, who is personally known to me or provided identification:



Signature of Notary: [Signature]
Name of Notary: Christie Kielty

City Code Sec. 2-279, Charges for consulting services established.

(a)The city manager or his/her designee, in the review of any application, may refer any such application presented to it to such engineering, planning, legal, technical, or environmental consultant or professionals employed by the city as the manager shall deem reasonably necessary to enable him to review such application as required by law. Charges made by such consultant shall be in accord with the charges customarily made for such services in the county, and pursuant to an existing contractual agreement by and between the city and such consultant. Charges made by the city shall be in accord with the hourly rates charged by such consultants or hourly rates of employed professionals and shall be paid on submission of a city voucher.(b)The applicant shall reimburse the city for the cost of such consultant or employed professional services upon submission of a copy of the voucher, within 30 days of submission of a copy of the voucher and as a condition of the zoning resolution. These fees are in addition to any and all other fees required by other law, rule, or regulation of this Code. (Ordinance No. 04-07)

I, JCP INTERNATIONAL I LLC, a Florida limited liability company (Property Owner), hereby acknowledge and consent to the payment of all applicable fees as it relates to the application and request for the review and processing of the requested Administrative Hearing, Public Hearing, or legal instrument. Fees shall include, but are not limited to review by city staff, city contractors, agents or consultants, advertisement(s), recordings, mailings, and any additional costs related to the submitted application.

Affidavit to be executed by property owner. All right and entitlements run with the property.

Owner's Name JCP INTERNATIONAL I LLC, a Florida limited liability company Signature [Signature] Date 10-15-25
Name Edward J. Easton
Title Manager

Notary to Owner: The foregoing instrument was acknowledged before me by means of physical presence or online notarization this 19 day of OCT, 2025 by Edward J. Easton as mgr. for JCP INTERNATIONAL I LLC, who is personally known to me or provided identification: _____

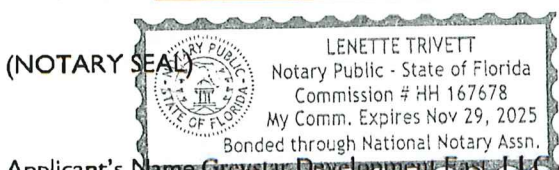

Signature of Notary: [Signature]
Name of Notary: Lenette Trivett

Applicant's Name Greystar Development East, LLC a Delaware limited liability company Signature [Signature] Date 10/7/2025
Lewis Stoneburner, Vice President

Notary to Applicant: The foregoing instrument was acknowledged before me by means of physical presence or online notarization this 7 day of October, 2025 by Lewis Stoneburner as Vice President for Greystar Development East, LLC, who is personally known to me or provided identification: _____



Signature of Notary: [Signature]
Name of Notary: Christie Kielty

PUBLIC HEARING, ADMINISTRATIVE REVIEW APPLICATION

COST RECOVERY AFFIDAVIT

City Code Sec. 2-279, Charges for consulting services established.

(a)The city manager or his/her designee, in the review of any application, may refer any such application presented to it to such engineering, planning, legal, technical, or environmental consultant or professionals employed by the city as the manager shall deem reasonably necessary to enable him to review such application as required by law. Charges made by such consultant shall be in accord with the charges customarily made for such services in the county, and pursuant to an existing contractual agreement by and between the city and such consultant. Charges made by the city shall be in accord with the hourly rates charged by such consultants or hourly rates of employed professionals and shall be paid on submission of a city voucher.(b)The applicant shall reimburse the city for the cost of such consultant or employed professional services upon submission of a copy of the voucher, within 30 days of submission of a copy of the voucher and as a condition of the zoning resolution. These fees are in addition to any and all other fees required by other law, rule, or regulation of this Code. (Ordinance No. 04-07)

I, West Dade County Associates, a Florida general partnership (Property Owner), hereby acknowledge and consent to the payment of all applicable fees as it relates to the application and request for the review and processing of the requested Administrative Hearing, Public Hearing, or legal instrument. Fees shall include, but are not limited to review by city staff, city contractors, agents or consultants, advertisement(s), recordings, mailings, and any additional costs related to the submitted application.

Affidavit to be executed by property owner. All right and entitlements run with the property.

Owner's Name West Dade County Associates, a Florida general partnership Signature [Signature] Date 3/14/26
Name John Rulli
Title Chief Administrative Officer

Notary to Owner: The foregoing instrument was acknowledged before me by means of physical presence or online notarization this 16th day of March, 2025 by John Rulli as CAO for West Dade County Associates, who is personally known to me or provided identification:

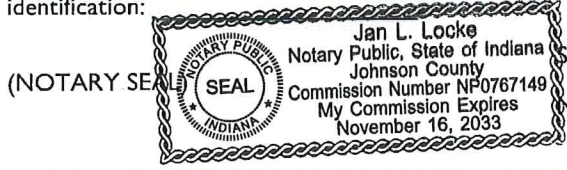

Signature of Notary: [Signature]
Name of Notary: Jan L. Locke

Applicant's Name Greystar Development East, LLC, a Delaware limited liability company Signature [Signature] Date 10/7/2025
Lewis Stoneburner, Vice President

Notary to Applicant: The foregoing instrument was acknowledged before me by means of physical presence or online notarization this 7 day of October, 2025 by Lewis Stoneburner as Vice President for Greystar Development East, LLC, who is personally known to me or provided identification:



Signature of Notary: [Signature]
Name of Notary: Christie Kielty

DISCLOSURE OF INTEREST*

If a **CORPORATION** owns or leases the subject property, list principal stockholders and percent of stock owned by each. [Note: Where principal officers or stockholders consist of other corporation(s), trust(s), partnership(s) or similar entities, further disclosure shall be made to identify the natural persons having the ultimate ownership interest].

CORPORATION NAME: _____

<u>NAME AND ADDRESS</u>	<u>Percentage of Stock</u>
_____	_____
_____	_____
_____	_____
_____	_____
_____	_____
_____	_____

If a **TRUST or ESTATE** owns or leases the subject property, list the trust beneficiaries and percent of interest held by each. [Note: Where beneficiaries are other than natural persons, further disclosure shall be made to identify the natural persons having the ultimate ownership interest].

TRUST/ESTATE NAME: _____

<u>NAME AND ADDRESS</u>	<u>Percentage of Interest</u>
_____	_____
_____	_____
_____	_____
_____	_____
_____	_____

If a **PARTNERSHIP** owns or leases the subject property, list the principals including general and limited partners. [Note: Where partner(s) consist of other partnership(s), corporation(s), trust(s) or similar entities, further disclosure shall be made to identify the natural persons having the ultimate ownership interests].

PARTNERSHIP OR LIMITED PARTNERSHIP NAME: EWE RETAIL II LTD, a Florida limited partnership

<u>NAME AND ADDRESS</u>	<u>Percent of Ownership</u>
Please see Exhibit C.	_____
_____	_____
_____	_____
_____	_____
_____	_____

DISCLOSURE OF INTEREST*

If a **CORPORATION** owns or leases the subject property, list principal stockholders and percent of stock owned by each. [Note: Where principal officers or stockholders consist of other corporation(s), trust(s), partnership(s) or similar entities, further disclosure shall be made to identify the natural persons having the ultimate ownership interest].

CORPORATION NAME: JCP INTERNATIONAL I LLC, a Florida limited liability company

<u>NAME AND ADDRESS</u>	<u>Percentage of Stock</u>
<u>Please see Exhibit D.</u>	<u></u>
<u></u>	<u></u>
<u></u>	<u></u>
<u></u>	<u></u>
<u></u>	<u></u>
<u></u>	<u></u>

If a **TRUST or ESTATE** owns or leases the subject property, list the trust beneficiaries and percent of interest held by each. [Note: Where beneficiaries are other than natural persons, further disclosure shall be made to identify the natural persons having the ultimate ownership interest].

TRUST/ESTATE NAME:

<u>NAME AND ADDRESS</u>	<u>Percentage of Interest</u>
<u></u>	<u></u>
<u></u>	<u></u>
<u></u>	<u></u>
<u></u>	<u></u>
<u></u>	<u></u>

If a **PARTNERSHIP** owns or leases the subject property, list the principals including general and limited partners. [Note: Where partner(s) consist of other partnership(s), corporation(s), trust(s) or similar entities, further disclosure shall be made to identify the natural persons having the ultimate ownership interests].

PARTNERSHIP OR LIMITED PARTNERSHIP NAME:

<u>NAME AND ADDRESS</u>	<u>Percent of Ownership</u>
<u></u>	<u></u>
<u></u>	<u></u>
<u></u>	<u></u>
<u></u>	<u></u>

If there is a **CONTRACT FOR PURCHASE** by a Corporation, Trust or Partnership, list purchasers below, including principal officers, stockholders, beneficiaries or partners. [Note: Where principal officers, stockholders, beneficiaries or partners consist of other corporations, trusts, partnerships or similar entities, further disclosure shall be made to identify natural persons having ultimate ownership interests].

NAME OF PURCHASER: _____

NAME, ADDRESS AND OFFICE (if applicable)	Percentage of Interest
_____	_____
_____	_____
_____	_____
_____	_____
_____	_____

Date of contract: _____

If any contingency clause or contract terms involve additional parties, list all individuals or officers, if a corporation, partnership or trust:

NOTICE: For changes of ownership or changes in purchase contracts after the date of the application, but prior to the date of final public hearing, a supplemental disclosure of interest is required.

The above is a full disclosure of all parties of interest in this application to the best of my knowledge and belief.

Signature:  Lewis Stoneburner, Vice President of Greystar Development East LLC
(Applicant)

Sworn to and subscribed before me this 7th day of October, 2005. Affiant is personally known to me or has produced _____ as identification.

(Notary Public)

My commission expires 11/12/2005

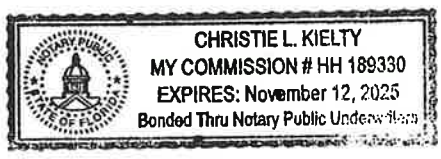

*Disclosure shall not be required of: 1) any entity, the equity interests in which are regularly traded on an established securities market in the United States or another country; or 2) pension funds or pension trusts of more than five thousand (5,000) ownership interests; or 3) any entity where ownership interests are held in a partnership, corporation or trust consisting of more than five thousand (5,000) separate interests, including all interests at every level of ownership and where no one (1) person or entity holds more than a total of five per cent (5%) of the ownership interest in the partnership, corporation or trust. Entities whose ownership interests are held in a partnership, corporation, or trust consisting of more than five thousand (5,000) separate interests, including all interests at every level of ownership, shall only be required to disclose those ownership interest which exceed five (5) percent of the ownership interest in the partnership, corporation or trust.

DISCLOSURE OF INTEREST*

If a **CORPORATION** owns or leases the subject property, list principal stockholders and percent of stock owned by each. [Note: Where principal officers or stockholders consist of other corporation(s), trust(s), partnership(s) or similar entities, further disclosure shall be made to identify the natural persons having the ultimate ownership interest].

CORPORATION NAME: _____

<u>NAME AND ADDRESS</u>	<u>Percentage of Stock</u>
_____	_____
_____	_____
_____	_____
_____	_____
_____	_____
_____	_____

If a **TRUST or ESTATE** owns or leases the subject property, list the trust beneficiaries and percent of interest held by each. [Note: Where beneficiaries are other than natural persons, further disclosure shall be made to identify the natural persons having the ultimate ownership interest].

TRUST/ESTATE NAME: _____

<u>NAME AND ADDRESS</u>	<u>Percentage of Interest</u>
_____	_____
_____	_____
_____	_____
_____	_____
_____	_____

If a **PARTNERSHIP** owns or leases the subject property, list the principals including general and limited partners. [Note: Where partner(s) consist of other partnership(s), corporation(s), trust(s) or similar entities, further disclosure shall be made to identify the natural persons having the ultimate ownership interests].

PARTNERSHIP OR LIMITED PARTNERSHIP NAME: West Dade County Associates, a Florida general partnership

<u>NAME AND ADDRESS</u>	<u>Percent of Ownership</u>
<u>Please see Exhibit E.</u>	_____
_____	_____
_____	_____
_____	_____

If there is a **CONTRACT FOR PURCHASE** by a Corporation, Trust or Partnership, list purchasers below, including principal officers, stockholders, beneficiaries or partners. [Note: Where principal officers, stockholders, beneficiaries or partners consist of other corporations, trusts, partnerships or similar entities, further disclosure shall be made to identify natural persons having ultimate ownership interests].

NAME OF PURCHASER: _____

NAME, ADDRESS AND OFFICE (if applicable)	Percentage of Interest
_____	_____
_____	_____
_____	_____
_____	_____
_____	_____

Date of contract: _____

If any contingency clause or contract terms involve additional parties, list all individuals or officers, if a corporation, partnership or trust:

NOTICE: For changes of ownership or changes in purchase contracts after the date of the application, but prior to the date of final public hearing, a supplemental disclosure of interest is required.

The above is a full disclosure of all parties of interest in this application to the best of my knowledge and belief.

Signature: [Signature] Lewis Stoneburner, Vice President of Greystar Development East LLC
(Applicant)

Sworn to and subscribed before me this 7th day of October, 2005. Affiant is personally known to me or has produced _____ as identification.

[Signature]
(Notary Public)



My commission expires 11/12/2005

*Disclosure shall not be required of: 1) any entity, the equity interests in which are regularly traded on an established securities market in the United States or another country; or 2) pension funds or pension trusts of more than five thousand (5,000) ownership interests; or 3) any entity where ownership interests are held in a partnership, corporation or trust consisting of more than five thousand (5,000) separate interests, including all interests at every level of ownership and where no one (1) person or entity holds more than a total of five per cent (5%) of the ownership interest in the partnership, corporation or trust. Entities whose ownership interests are held in a partnership, corporation, or trust consisting of more than five thousand (5,000) separate interests, including all interests at every level of ownership, shall only be required to disclose those ownership interest which exceed five (5) percent of the ownership interest in the partnership, corporation or trust.

Exhibit A
List of Property Owners

Property No. 1

Address: 1625 NW 107 Avenue, Miami Florida

Folio No.: 35-3032-008-0050

Owner: EWE RETAIL II LTD, a Florida limited partnership
10165 NW 19 Street,
Doral, Florida 33172

Acquired: October 10, 2024

Property No. 2

Address: 1603 NW 107 Avenue, Miami Florida

Folio No.: 35-3032-008-0140

Owner: JCP INTERNATIONAL I LLC, a Florida limited liability company
10165 NW 19 Street,
Doral, Florida 33172

Acquired: October 1, 2024

Property No. 3

Folio No.: 35-3032-008-0010

Owner: West Dade County Associates, a Florida general partnership
115 W Washington Street, Suite 15E
Indianapolis, IN 46204

Acquired: January 22, 1981

Exhibit B

DISCLOSURE OF INTEREST

Greystar Development East, LLC (465 Meeting St. Ste 500, Charleston, SC 29403)

Directors/Officers:	Robert A. Faith
	J. Derek Ramsey
	Ashley Heggie
	Matthew Warren
	Todd Wigfield
	Lewis Stoneburner
	Kristin Schul
	Michael Sullivan
	Kurt Wolber
	George Hayward
	John Clarkson
	Darin Cook
	Joshua Glover
	Gary Kerr
	David King
	Ben Liebetrau
	John Roberson
	Julie Skolnicki
	Christopher Mazzola

GREYSTAR DEVELOPMENT EAST, LLC IS AN LLC CONSISTING OF MORE THAN 5,000 SEPARATE INTERESTS, INCLUDING ALL INTEREST AT EVERY LEVEL OF OWNERSHIP, WHERE NO ONE PERSON OR ENTITY HOLDS MORE THAN A FIVE PERCENT OWNERSHIP INTEREST IN THE LLC, WITH THE EXCEPTION OF ROBERT A. FAITH, WHOSE OVERALL INTEREST IS IN EXCESS OF FIVE PERCENT.

Exhibit C Disclosure of Interest

EWE RETAIL II, LTD (SEARS) OWNERSHIP

INVESTORS	PERCENTAGE INTEREST	CAPITAL
Amy Kelly-Easton	0.35714%	50,000.00
Andrew R. Easton	1.42857%	200,000.00
Cannon Miami LLC (Andrew Rosen)	10.71429%	1,500,000.00
Christopher V. Damian Revocable Trust	2.14286%	300,000.00
Collin J. Easton	0.17857%	25,000.00
Daniel L. Easton	0.17857%	25,000.00
Daniel Shenkman	1.78571%	250,000.00
David Wilf	0.35714%	50,000.00
Easton Real Estate Holdings, LLC	3.03571%	425,000.00
Edward Dalton Easton	1.42857%	200,000.00
Edward J. Easton	1.07143%	150,000.00
Edward W. Easton	1.07143%	150,000.00
Edward W. Easton Family, Ltd	8.57143%	1,200,000.00
ELE Investment Group, LLC	0.53571%	75,000.00
Furman Family Holding LLC	3.57143%	500,000.00
Gary & Tamara Braverman	7.14286%	1,000,000.00
Harrison Easton	0.17857%	25,000.00
Ira London	0.71429%	100,000.00
Jake Weiss LLC	0.53571%	75,000.00
Mahalo Partners, LLC	3.57143%	500,000.00
Mark L. & Tobi R. Weiss TBE	0.71429%	100,000.00
Martin Silver, Trustee of Martin Silver Revocable Trust	3.57143%	500,000.00
Michael L. Shenkman	1.78571%	250,000.00
Jill Braufman 2017 Family Trust	10.71429%	1,500,000.00
Shenkman Partners LLC	7.14286%	1,000,000.00
Control Limited Partnership (Stig Wennerstrom)	1.96429%	275,000.00
Melanie A. Mochan	0.17857%	25,000.00
Three Bears, LLC	0.35714%	50,000.00
EWE Retail II LLC (General Partner)	25.00000%	
TOTAL	100.0000%	10,500,000.00

EWE RETAIL II, LLC	PERCENTAGE INTEREST
Edward W. Easton	33.3333%
Edward J. Easton	33.3334%
Gary Braverman	33.3333%
	100.000%

GENERAL
PARTNER

Exhibit D
Disclosure of Interest

JCP INTERNATIONAL I, LLC

**SINGLE MEMBER, OWNED 100% BY
DD WAREHOUSE INVESTMENTS I, LTD**

DD Warehouse Investments I, Ltd	PERCENTAGE INTEREST	CAPITAL
Furman Family Holdings LLC	18.75000%	450,000.00
Stig Wennerstrom Revocable Trust	8.33333%	200,000.00
Edward W. Easton Family Limited	12.50000%	300,000.00
Easton Real Estate Holdings LLC	14.58333%	350,000.00
Gary & Tamara Braverman	12.50000%	300,000.00
Danielle Braverman	2.08333%	50,000.00
Andrew Easton	2.08333%	50,000.00
Elliot LaBreche	2.08333%	50,000.00
HSRE Holdings, LLC	2.08333%	50,000.00
 DD Warehouse Investments I, LLC (GP)	 25.0000%	
TOTAL	100.0000%	1,800,000.00

DD Warehouse Investments I, LLC	PERCENTAGE INTEREST
Dalton Easton	16.00000%
Gary & Tamara Braverman	25.22000%
Edward W. Easton	25.22000%
Edward J. Easton	12.61000%
The Robbi D. Easton Irrevocable Trust	12.61000%
Andrew Easton	2.78000%
Elliot LaBreche	2.78000%
HSRE Holdings, LLC	2.78000%
TOTAL	100.0000%

GENERAL
PARTNER

EXHIBIT E

West Dade County Associates, a Florida general partnership

Simon Property Group, L.P., an Indiana limited partner, its managing partner – 100%

*Simon Property Group, Inc., an Indiana corporation, its general partner – 100%

*Simon Property Group, Inc., is an entity in which the equity interests are regularly traded on an established security market in the United States (NYSE).

LEGAL DESCRIPTION

THE PROPERTY

A PART OF TRACT A, MIAMI INTERNATIONAL MALL PROPERTIES, ACCORDING TO THE PLAT RECORDED IN PLAT BOOK 117, PAGE 84, PUBLIC RECORDS OF MIAMI-DADE COUNTY, FLORIDA, AND BEING MORE PARTICULARLY DESCRIBED AS FOLLOWS:

BEGINNING AT A PIPE IN CONCRETE MARKING THE SOUTHWEST CORNER OF SAID SECTION 32, TOWNSHIP 53 SOUTH, RANGE 40 EAST; THENCE, NORTH 89° 20' 55" EAST, ALONG THE SOUTH LINE OF SECTION 32, FOR A DISTANCE OF 2250.00 FEET TO A POINT; THENCE, NORTH 01° 43' 13" WEST FOR A DISTANCE OF 1149.03 FEET TO A POINT; THENCE, SOUTH 88° 16' 47" WEST FOR A DISTANCE OF 45.00 FEET TO A POINT; THENCE, NORTH 01° 43' 13" WEST FOR A DISTANCE OF 263.14 FEET TO A POINT, SAID POINT BEING THE PRINCIPAL POINT AND PLACE OF BEGINNING OF THE FOLLOWING DESCRIPTION; THENCE, DUE WEST FOR A DISTANCE OF 244.73 FEET TO A POINT; THENCE, DUE NORTH FOR A DISTANCE OF 102.00 FEET TO A POINT; THENCE, DUE WEST FOR A DISTANCE OF 432.00 FEET TO A POINT; THENCE, DUE NORTH FOR A DISTANCE OF 386.97 FEET TO A POINT; THENCE, NORTH 45° 00' 00" EAST FOR A DISTANCE OF 100.46 FEET TO A POINT; THENCE, DUE WEST FOR A DISTANCE OF 472.87 FEET TO A POINT; THENCE, SOUTH 45° 00' 00" WEST FOR A DISTANCE OF 171.25 TO A POINT; THENCE NORTH 45° 00' 00" WEST FOR A DISTANCE OF 413.50 FEET TO A POINT; THENCE; SOUTH 45° 00' 00" WEST FOR A DISTANCE OF 16.00 FEET TO A POINT; THENCE, NORTH 45° 00' 00" WEST FOR A DISTANCE OF 60.63 FEET TO A POINT IN THE INNER EDGE OF PERMANENT ACCESS EASEMENT, AS DESCRIBED IN OFFICIAL RECORD BOOK 11411 AT PAGE 1044 OF THE PUBLIC RECORDS OF MIAMI-DADE COUNTY FLORIDA; THENCE, NORTH 45° 00' 00" EAST, ALONG THE SAID INNER EDGE OF PERMANENT ACCESS EASEMENT, FOR A DISTANCE OF 29.00 FEET; THENCE, NORTH 45° 00' 00" WEST, AT RIGHT ANGLES TO LAST DESCRIBED COURSE, FOR A DISTANCE OF 64.00 FEET TO A POINT; THENCE, NORTH 45° 00' 00" EAST FOR A DISTANCE OF 538.58 FEET TO A POINT (LAST MENTIONED COURSE BEING ALONG THE SOUTHEASTERLY BOUNDARY LINE OF PARCEL VI-E AND ITS SOUTHWESTERLY EXTENSION, AS DESCRIBED IN OFFICIAL RECORD BOOK 11638, AT PAGE 1229 OF THE PUBLIC RECORDS OF MIAMI-DADE COUNTY FLORIDA); THENCE, NORTH 89° 38' 52" EAST, ALONG THE NORTH LINE OF THE SOUTHWEST 1/4 OF SECTION 32, TOWNSHIP 53 SOUTH, RANGE 40 EAST, FOR A DISTANCE OF 661.69 FEET TO A POINT; THENCE, SOUTH 45° 00' 00" WEST FOR A DISTANCE OF 53.79 FEET; THENCE, SOUTH 45° 00' 00" EAST FOR DISTANCE OF 721.50 FEET TO A POINT; THENCE, NORTH 45° 00' 00" EAST FOR A DISTANCE OF 105.72 FEET TO A POINT; THENCE, SOUTH 01° 43' 13" EAST FOR A DISTANCE OF 725.88 FEET TO A POINT; THENCE, SOUTH 88° 16' 47" WEST, AT RIGHT ANGLES TO LAST DESCRIBED



COURSE, FOR A DISTANCE OF 10.00 FEET TO A POINT; THENCE, SOUTH 01° 43' 13" EAST, AT RIGHT ANGLES TO LAST DESCRIBED COURSE, FOR A DISTANCE OF 17.42 FEET TO A POINT; THENCE, SOUTH 88° 16' 47" WEST, AT RIGHT ANGLES TO LAST DESCRIBED COURSE, FOR A DISTANCE OF 35.00 FEET TO THE POINT OF BEGINNING.

SAID PARCEL CONTAINING 1,115,703 SQ.FT (25.612 ACRES) MORE OR LESS.

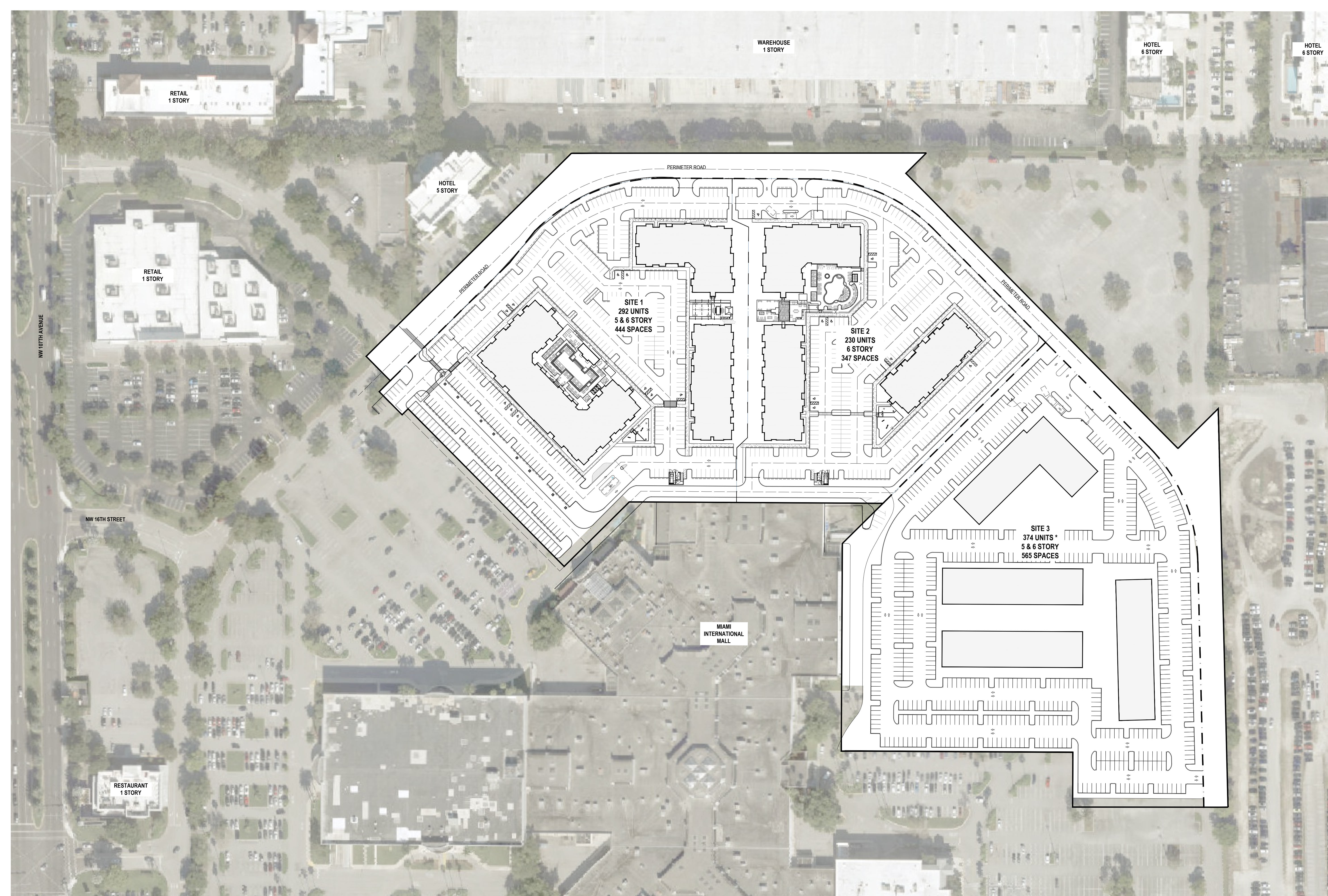
LYING AND BEING IN SECTION 32, TOWNSHIP 53 SOUTH, RANGE 40 EAST, MIAMI-DADE COUNTY, FLORIDA.



SITE DATA	
Property location	Miami International Mall
Folio	35-3032-008-0050, 35-3032-008-0010 35-3032-008-0140
Zoning District	Mall Mixed-Use
Future Land Use	Mall Mixed-Use
Proposed Use	Multifamily Residential
Site Area	1,115,659 sf 25.612 acres
Density*	
Minimum	30.0 du/ac 770.0 units
Maximum	35.0 du/ac 896.0 units
* Site 1 & Site 2: Maximum 522 units permitted in accordance with Sec. 86-83 (Creative Excellence).	
* Site 3: Minimum of 248 units provided without density increase under Creative Excellence standards.	

 PROPERTY LINE
 LIMITS OF RESIDENTIAL PROJECT



DESIGNED FOR
THE EASTON GROUP & GREYSTAR

MIAMI INTERNATIONAL MALL
DORAL, FL



CONCEPTUAL SITE PLAN FOR RESIDENTIAL SITES
AT MIAMI INTERNATIONAL MALL

DATE: 05/05/2026

SCALE: 1" = 80'

COPYRIGHT 2025 MSA ARCHITECTS, INC. THE ARCHITECTURAL DESIGN AND DETAIL DWGS. FOR THIS BLOG, AND/OR OVERALL PROJECT ARE THE LEGAL PROPERTY OF AND ALL RIGHTS ARE RESERVED BY THE ARCHITECT. THEIR USE FOR REPRODUCTION, CONSTRUCTION OR DISTRIBUTION IS PROHIBITED UNLESS AUTHORIZED IN WRITING BY THE ARCHITECT.

LEGEND AND ABBREVIATIONS			
	CONCRETE POLE		HANDICAP PAINT MARK
	CONCRETE POWER POLE		BABY STROLLER PAINT MARK
	CONCRETE LIGHT POLE		UNKNOWN MANHOLE
	ALUMINUM POLE		WATER MANHOLE
	ALUMINUM LIGHT POLE		SEWER MANHOLE
	WOOD POLE		PHONE MANHOLE
	WOOD POWER POLE		IRRIGATION MANHOLE
	WOOD LIGHT POLE		GREASE TRAP MANHOLE
	TRAFFIC BOX		GAS MANHOLE
	STREET LIGHT BOX		FIREMAN MANHOLE
	PHONE BOX		ELECTRICITY MANHOLE
	IRRIGATION BOX		DRAINAGE MANHOLE
	ELECTRIC BOX		COMMUNICATION MANHOLE
	COMMUNICATION BOX		BELL SOUTH MANHOLE
	CABLE TV BOX		PARKING METER
	UNKNOWN BOX		PARKING KIOSK
	TRAFFIC CONTROL BOX		WATER VALVE
	CLEANOUT		SEWER VALVE
	BOLLARD		IRRIGATION VALVE
	ARM GATE		GAS VALVE
	CHECK VALVE		FORCE MAIN VALVE
	WATER METER		SEWER MANHOLE ASSEMBLY
	IRRIGATION METER		SEWAGE CONNECTION
	GAS METER		POST INDICATOR VALVE
	ELECTRIC METER		FIRE HYDRANT
	SQUARE COLUMN		PERMANENT CONTROL POINT
	ROUND COLUMN		PERMANENT REFERENCE MONUMENT
	MAIL BOX		FLAT BOOK AND PAGE
	IRRIGATION PUMP		OVERHEAD UTILITY WIRES
	GUARD POST		OFFICIAL RECORDS BOOK
	GROUND LIGHT		CONCRETE BLOCK STRUCTURE
	FLAG POLE		CONCRETE
	DRAINAGE WELL		CHAIN LINK FENCE
	SQUARE DRAINAGE		WOOD FENCE
	PS INLET		FOUND IRON PIPE
	CURB INLET		FOUND METAL OR BRASS DISC
	CIRCULAR DRAINAGE		CLEAR
	CATCH BASIN		ENCROACHMENT
	ACCESS MANHOLE		EASEMENT OR LEGAL DISTANCE
	SMILE INLET		MEASURED DISTANCE
	TRAFFIC SIGNAL POLE		RECORD OR PLATTED DISTANCE
	TRAFFIC SIGN		RECORD CALCULATED
	SURVEILLANCE CAMERA		UTILITY EASEMENT
	PEDESTRIAN CROSS SIGNAL		CONCRETE
	PAVEMENT ASPHALT		CONCRETE
	PAVEMENT PALM		CONCRETE
	PAVEMENT TREE		CONCRETE

AREAS	
SEARS SITE	SUBJECT PROPERTY AREA: 565,951 SQ. FT. (12.992 ACRES)
JC PENNY SITE	SUBJECT PROPERTY AREA: 419,055 SQ. FT. (9.620 ACRES)
PARCEL K1	SUBJECT PROPERTY AREA: 6,276 SQ. FT. (0.144 ACRES)
PARCEL K2	SUBJECT PROPERTY AREA: 9,734 SQ. FT. (0.223 ACRES)
PARCEL K3	SUBJECT PROPERTY AREA: 897 SQ. FT. (0.021 ACRES)
PARCEL K4	SUBJECT PROPERTY AREA: 19,036 SQ. FT. (0.437 ACRES)
PARCEL K5	SUBJECT PROPERTY AREA: 4,114 SQ. FT. (0.101 ACRES)
A PORTION OF PERMANENT ACCESS EASEMENT	SUBJECT PROPERTY AREA: 90,340 SQ. FT. (2.074 ACRES)
TOTAL AREA:	1,115,703 SQ. FT. (25.612 ACRES)

SURVEYOR'S NOTES

- FIELD SURVEY WAS COMPLETED ON: APRIL 29, 2025 AND UPDATED ON: SEPTEMBER 23, 2025.
- LEGAL DESCRIPTION WAS PROVIDED BY THE CLIENT.
- SUBJECT PROPERTY AREA: SEARS SITE: 565,951 SQ. FT. (12.992 ACRES); JC PENNY SITE: 419,055 SQ. FT. (9.620 ACRES); PARCEL K1: 6,276 SQ. FT. (0.144 ACRES); PARCEL K2: 9,734 SQ. FT. (0.223 ACRES); PARCEL K3: 897 SQ. FT. (0.021 ACRES); PARCEL K4: 19,036 SQ. FT. (0.437 ACRES); PARCEL K5: 4,114 SQ. FT. (0.101 ACRES); A PORTION OF PERMANENT ACCESS EASEMENT: 90,340 SQ. FT. (2.074 ACRES).
- SEARINGS BASED ON AN ASSUMED BEARING OF EAST ALONG THE NORTH LINE OF SUBJECT PROPERTY SITE #1.
- DISTANCES ALONG BOUNDARY LINES AS SHOWN HEREON ARE RECORD AND/OR MEASURED UNLESS OTHERWISE NOTED.
- INTERIOR LOT LINES AS SHOWN HEREON ARE FOR INFORMATIONAL PURPOSES ONLY UNLESS OTHERWISE NOTED.
- UNDERGROUND FOOTINGS, FOUNDATIONS AND HAVE NOT BEEN LOCATED AT THE TIME OF THIS SURVEY UNLESS OTHERWISE NOTED.
- ABOVEGROUND AND/OR VISIBLE UTILITIES HAVE BEEN LOCATED AT THE TIME OF THIS SURVEY, UNLESS OTHERWISE NOTED.
- SUBJECT PROPERTY HAS A DIRECT PHYSICAL ACCESS TO AND FROM PERMANENT ACCESS EASEMENT.
- THE SURVEYOR'S NOT DETERMINE FENCE AND/OR WALL OWNERSHIP.
- THERE IS A GAP BETWEEN SEARS SITE AND PERMANENT ACCESS EASEMENT.
- THIS BOUNDARY SURVEY IS SUBJECT TO EASEMENTS, RIGHTS-OF-WAY AND OTHER MATTERS THAT MIGHT BE REFLECTED ON A SEARCH OF TITLE OF THE SUBJECT PROPERTY.

PROPERTY INFORMATION

SEARS SITE

- PROPERTY ADDRESS: 1625 NW 107th AVE, CITY OF DORAL, MIAMI-DADE, FL 33172
- PARCEL ID: 35-3032-008-0050

JC PENNY SITE

- PROPERTY ADDRESS: 1933 NW 107th AVE, CITY OF DORAL, MIAMI-DADE, FL 33172
- PARCEL ID: 35-3032-008-0140

CERTIFY TO:

- GREYSTAR DEVELOPMENT EAST, LLC, A DELAWARE LIMITED LIABILITY COMPANY.
- FIRST AMERICAN TITLE INSURANCE COMPANY.
- GREENBERG TRAURIG, PA.

DATUM AND BENCHMARKS

- ELEVATIONS SHOWN HEREON REFER TO NATIONAL GEODETIC VERTICAL DATUM OF 1929 (N.G.V.D. 1929) AND ARE EXPRESSED IN FEET.
- BENCHMARK: NAME: H-452; ELEVATION: 8.72' N.G.V.D.; DESCRIPTION: 8" NAIL AND ALUMINUM WASHER SET ON CONC. SIDEWALK.

FLOOD ZONE INFORMATION

- SUBJECT PROPERTY IS LOCATED WITHIN FLOOD ZONE "AH" (EL. 8 FEET) AND ZONE "X" AS SHOWN ON FLOOD INSURANCE RATE MAP NUMBER 12082C0086L, DATED ON SEPTEMBER 11, 2009.
- ELEVATION REFER TO NATIONAL GEODETIC VERTICAL DATUM OF 1929 AND IS EXPRESSED IN FEET.

REVISIONS			
DATE	JOB No.	REV.	BY
05/27/25	155116	UPDATE TITLE OF COMMITMENT	C.A.F.
09/23/25	155443-S	UPDATE BOUNDARY SURVEY	C.A.F.
06/11/25	155443-S	UPDATE BOUNDARY SURVEY	C.A.F.

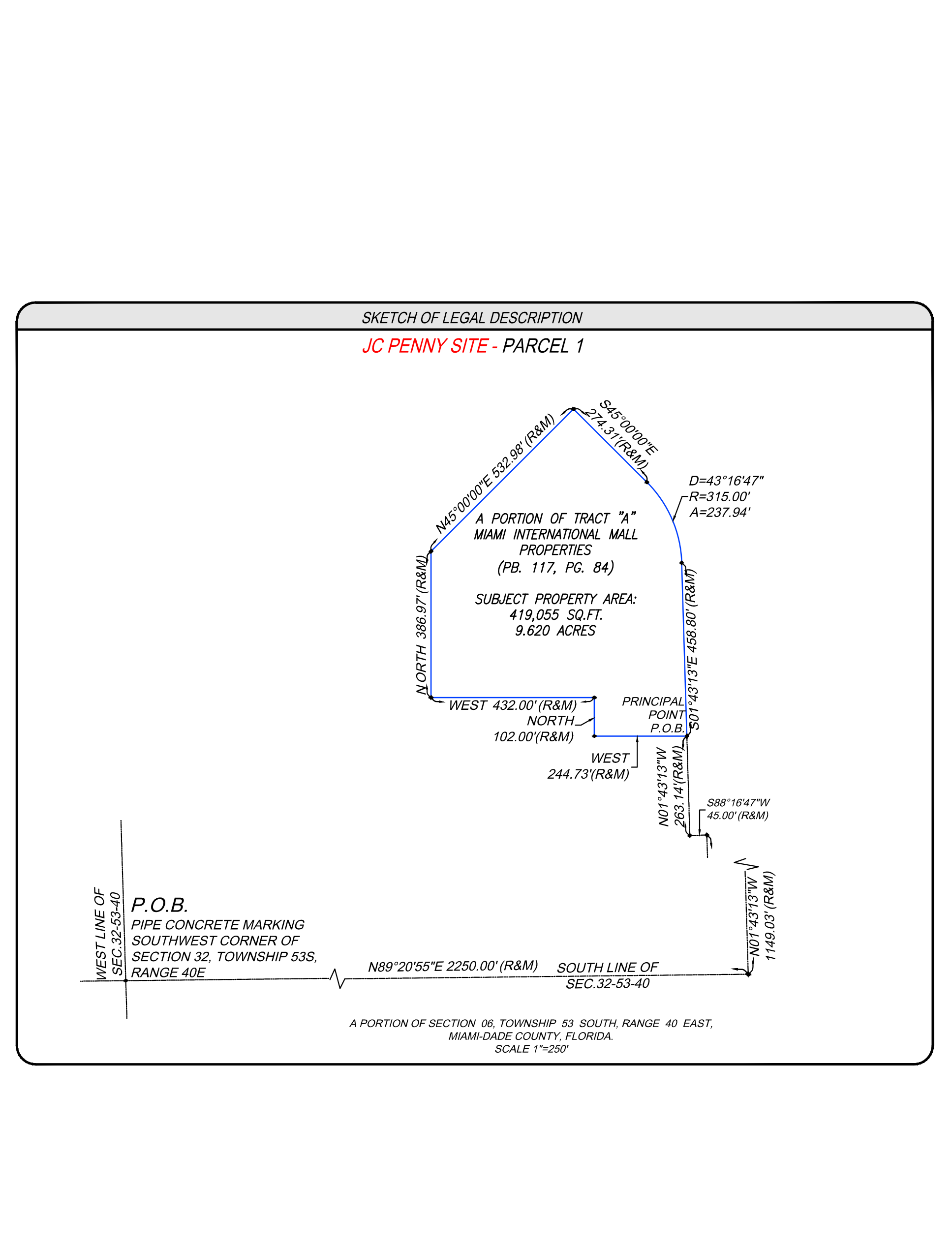
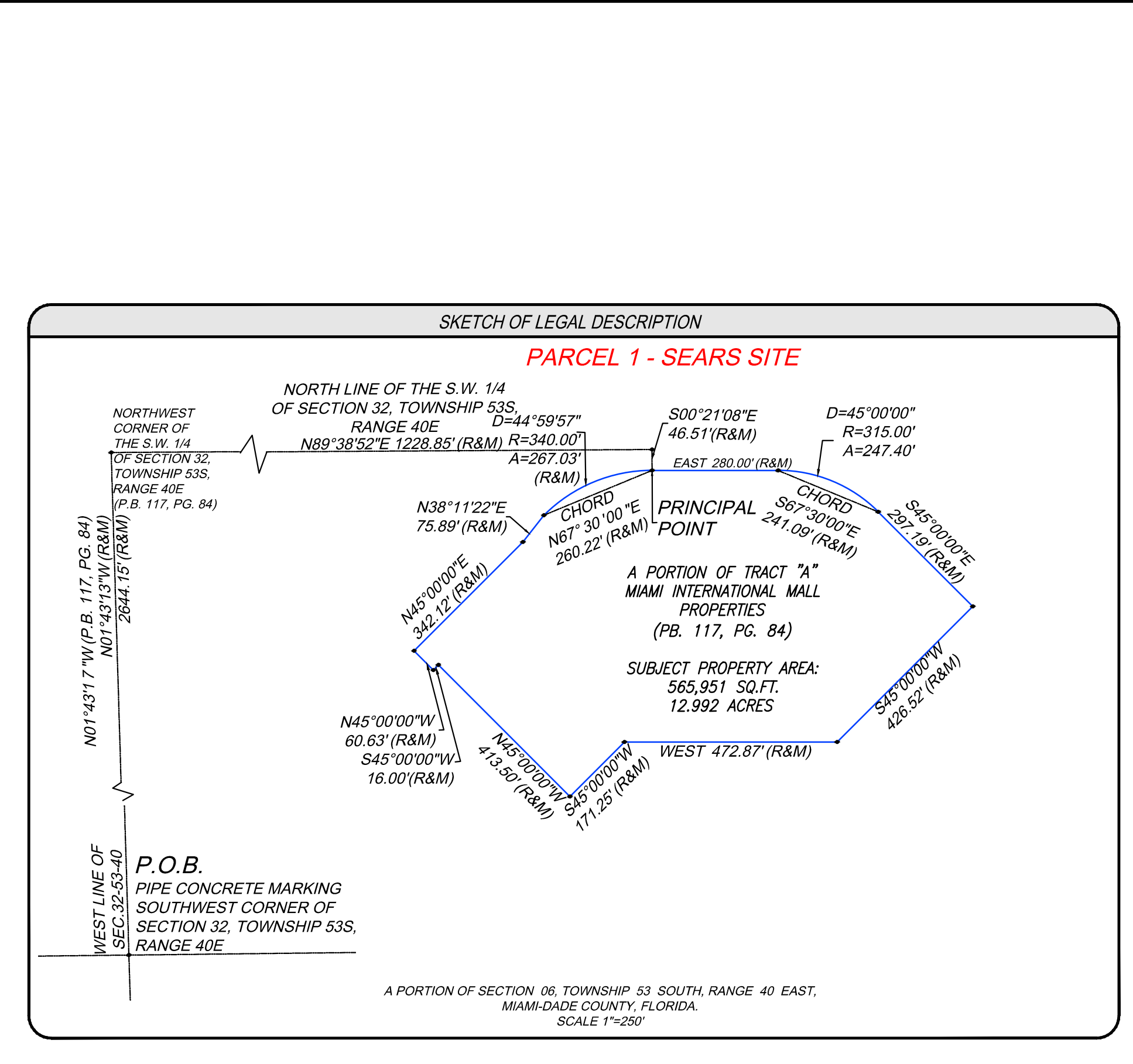
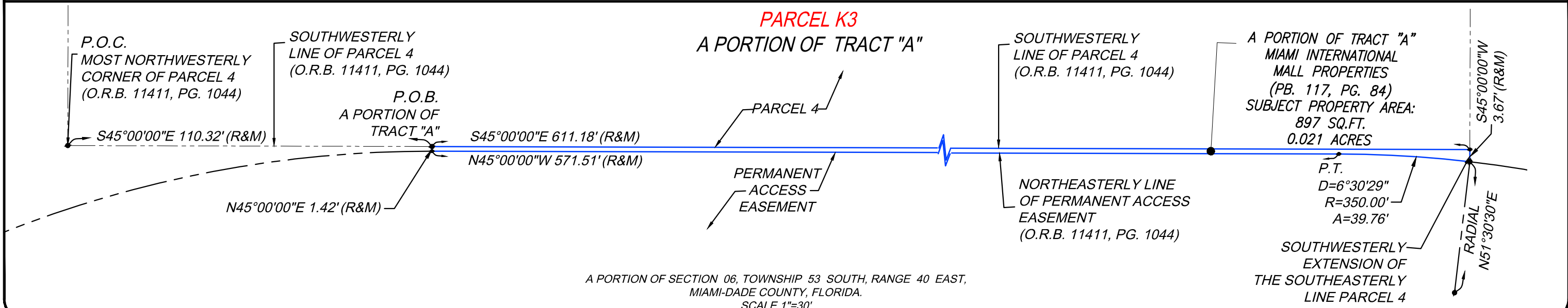
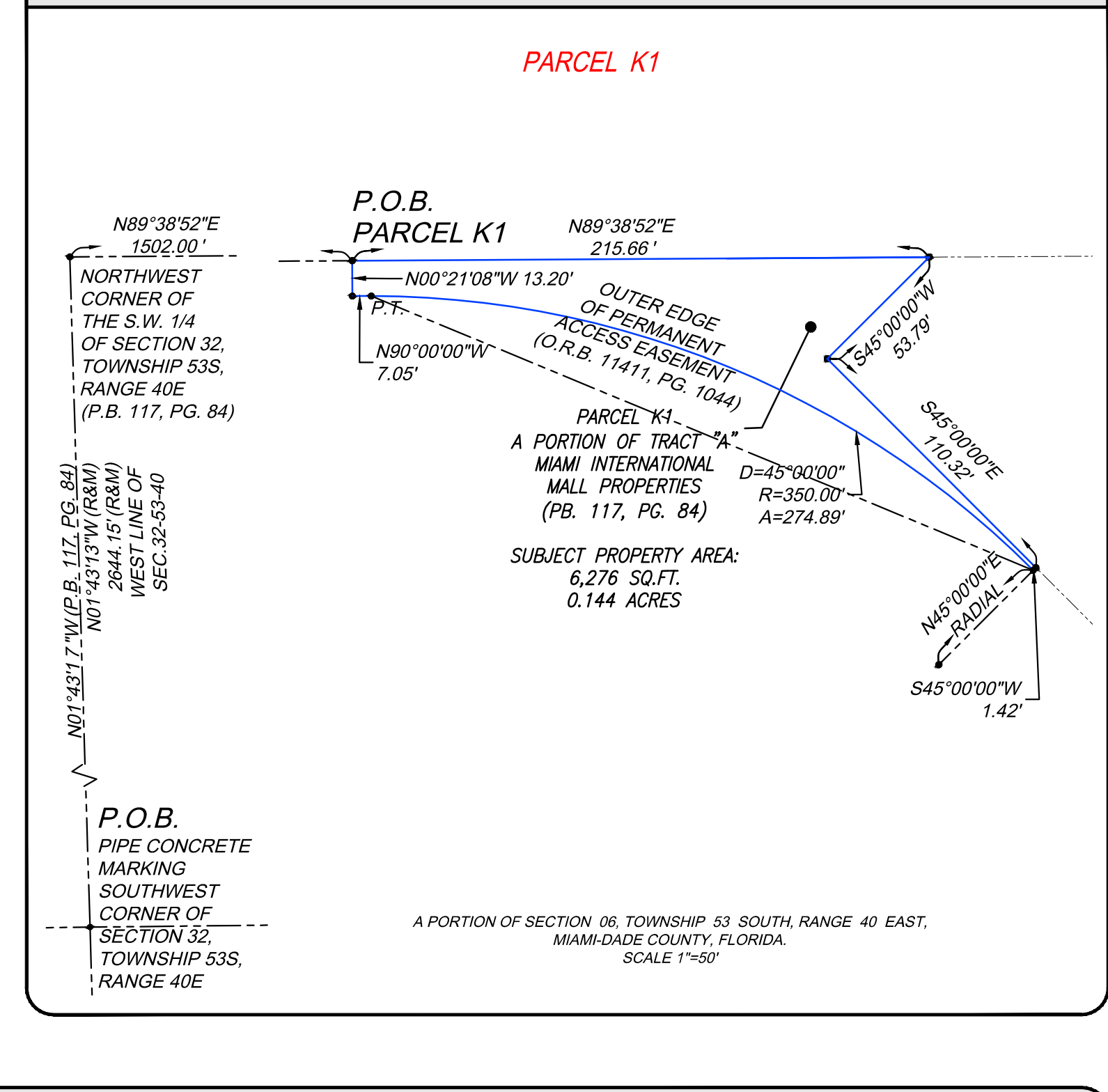
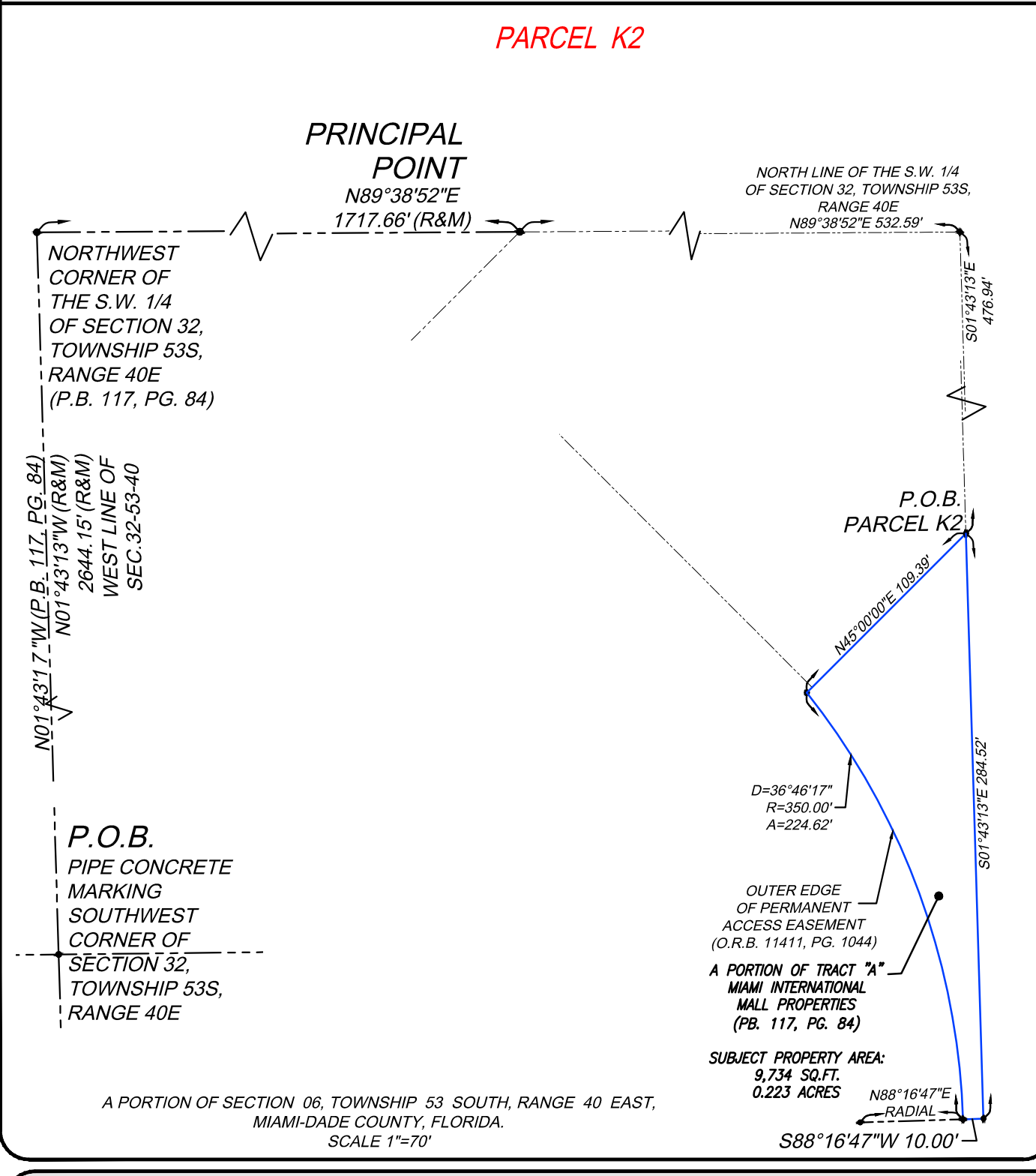
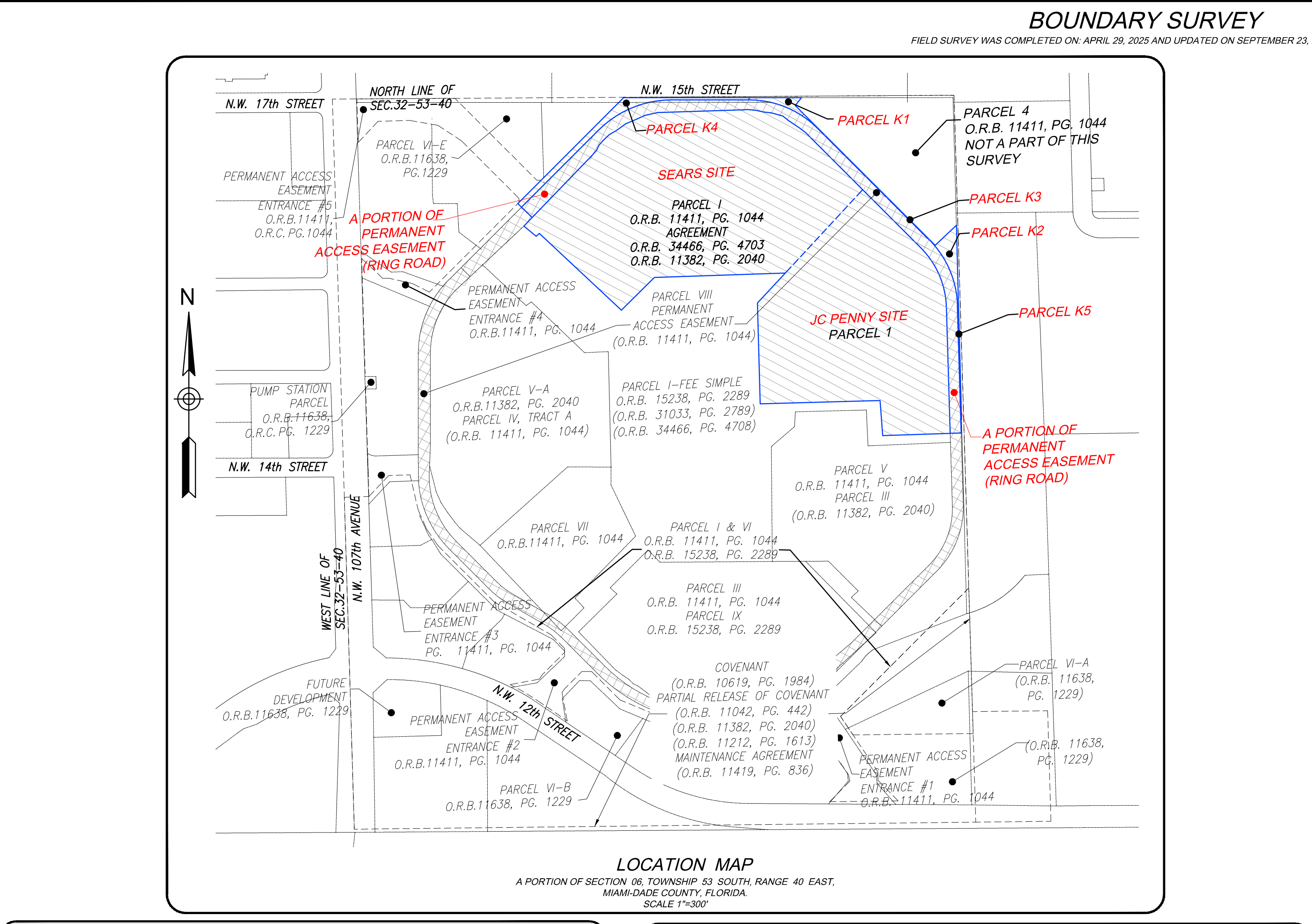

BOUNDARY SURVEY

PREPARED FOR:
GREYSTAR DEVELOPMENT EAST, LLC
LYING AND BEING IN SECTION 32, TOWNSHIP 53 SOUTH, RANGE 40 EAST
CITY OF DORAL, MIAMI-DADE COUNTY, FLORIDA.

J. Hernandez & Associates Inc.
LAND SURVEYORS AND MAPPERS
CERTIFICATE OF AUTHORIZATION No. LB8092
3300 NW 112th AVE, SUITE #10, DORAL, FL 33172
(P) 305-526-0266 (E) jh@jhsurveyors.com

DRAWN BY: C.A.F. CHECKED BY: J.G.H. JOB NUM: 155116
DATE: 05/01/2025 DATE: 05/01/2025 F.B. MD-80, PG. 30

LEGAL DESCRIPTION

SEARS SITE

A PORTION OF LAND LOCATED WITHIN SECTION 32, TOWNSHIP 53 SOUTH, RANGE 40 EAST, MIAMI-DADE COUNTY, FLORIDA, AND FURTHER BOUNDARIES AND DESCRIPTIONS AS FOLLOWS:

COMMENCE AT THE NORTHWEST CORNER OF THE S.W. 1/4 OF SECTION 32, TOWNSHIP 53S, RANGE 40E (P.B. 117, PG. 84); THENCE N89°38'52"E 1228.85' (R&M) R=340.00' A=267.03' (R&M); THENCE EAST 280.00' (R&M); THENCE S00°21'08"E 46.51' (R&M); THENCE D=45°00'00" R=315.00' A=247.40'; THENCE S45°00'00"E 241.05' (R&M); THENCE S45°00'00"E 426.52' (R&M); THENCE S45°00'00"W 426.52' (R&M); THENCE N45°00'00"W 171.25' (R&M); THENCE N45°00'00"W 16.03' (R&M); THENCE N45°00'00"W 60.63' (R&M); THENCE N45°00'00"E 342.12' (R&M); THENCE N38°11'22"E 75.89' (R&M); THENCE TOGETHER WITH PARCEL 1 TO THE NORTHWEST CORNER OF THE S.W. 1/4 OF SECTION 32, TOWNSHIP 53S, RANGE 40E (P.B. 117, PG. 84).

PARCEL 1 - SEARS SITE

A PORTION OF TRACT "A" MAMI INTERNATIONAL MALL PROPERTIES (P.B. 117, PG. 84) SUBJECT PROPERTY AREA: 565,951 SQ. FT. 12.992 ACRES.

PARCEL 1 - JC PENNY SITE

A PORTION OF TRACT "A" MAMI INTERNATIONAL MALL PROPERTIES (P.B. 117, PG. 84) SUBJECT PROPERTY AREA: 419,055 SQ. FT. 9.620 ACRES.

PARCEL K1

A PORTION OF TRACT "A" MAMI INTERNATIONAL MALL PROPERTIES (P.B. 117, PG. 84) SUBJECT PROPERTY AREA: 6,276 SQ. FT. 0.144 ACRES.

PARCEL K2

A PORTION OF TRACT "A" MAMI INTERNATIONAL MALL PROPERTIES (P.B. 117, PG. 84) SUBJECT PROPERTY AREA: 9,734 SQ. FT. 0.223 ACRES.

PARCEL K3

A PORTION OF TRACT "A" MAMI INTERNATIONAL MALL PROPERTIES (P.B. 117, PG. 84) SUBJECT PROPERTY AREA: 897 SQ. FT. 0.021 ACRES.

PARCEL K4

A PORTION OF TRACT "A" MAMI INTERNATIONAL MALL PROPERTIES (P.B. 117, PG. 84) SUBJECT PROPERTY AREA: 19,036 SQ. FT. 0.437 ACRES.

PARCEL K5

A PORTION OF TRACT "A" MAMI INTERNATIONAL MALL PROPERTIES (P.B. 117, PG. 84) SUBJECT PROPERTY AREA: 4,114 SQ. FT. 0.101 ACRES.

A PORTION OF PERMANENT ACCESS EASEMENT (RING ROAD)

A PORTION OF PERMANENT ACCESS EASEMENT, AS SHOWN IN OFFICIAL RECORD BOOK 11411, PAGE 104 OF THE PUBLIC RECORDS OF MIAMI-DADE COUNTY, AND BEING MORE PARTICULARLY DESCRIBED AS FOLLOWS:

COMMENCE AT THE NORTHWEST CORNER OF THE S.W. 1/4 OF SECTION 32, TOWNSHIP 53 SOUTH, RANGE 40 EAST, AS SHOWN ON SAID PLAT OF MAMI INTERNATIONAL MALL PROPERTIES (P.B. 117, PG. 84); THENCE N89°38'52"E 1228.85' (R&M) R=340.00' A=267.03' (R&M); THENCE EAST 280.00' (R&M); THENCE S00°21'08"E 46.51' (R&M); THENCE D=45°00'00" R=315.00' A=247.40'; THENCE S45°00'00"E 241.05' (R&M); THENCE S45°00'00"E 426.52' (R&M); THENCE S45°00'00"W 426.52' (R&M); THENCE S45°00'00"W 171.25' (R&M); THENCE S45°00'00"W 16.03' (R&M); THENCE S45°00'00"W 60.63' (R&M); THENCE S45°00'00"E 342.12' (R&M); THENCE N38°11'22"E 75.89' (R&M); THENCE TOGETHER WITH PARCEL 1 TO THE NORTHWEST CORNER OF THE S.W. 1/4 OF SECTION 32, TOWNSHIP 53S, RANGE 40E (P.B. 117, PG. 84).

SURVEYOR'S CERTIFICATION:

I HEREBY CERTIFY THAT THIS "BOUNDARY SURVEY" OF THE PROPERTY DESCRIBED HEREON IS TRUE AND CORRECT TO THE BEST OF MY KNOWLEDGE AND BELIEF AS RECENTLY SURVEYED AND DRAWN UNDER MY SUPERVISION AND DIRECTION. THIS SURVEY COMPLIES WITH STANDARDS OF PRACTICE REQUIREMENTS ADOPTED BY THE FLORIDA STATE BOARD OF SURVEYORS AND MAPPERS, PURSUANT TO CHAPTER 35-17, FLORIDA ADMINISTRATIVE CODE.

THIS CERTIFICATION DOES NOT EXTEND TO ANY UNNAMED PARTIES.

BY:

JOSE G. HERNANDEZ, PRESIDENT
PROFESSIONAL LAND SURVEYOR NO. 8952
STATE OF FLORIDA.

THE ELECTRONIC SEAL AND SIGNATURE APPEARING ON THIS SURVEY WAS AUTHORIZED BY JOSE G. HERNANDEZ, PROFESSIONAL LAND SURVEYOR NO. 8952 OF THE STATE OF FLORIDA ON MARCH 24, 2025.

THIS IS A BOUNDARY SURVEY
PROJECT NUMBER: MD-746
SHEET NUMBER: 1 OF 13

LEGEND AND ABBREVIATIONS			
	CONCRETE POLE		HANDICAP PAINT MARK
	CONCRETE POWER POLE		BABY STROLLER PAINT MARK
	CONCRETE LIGHT POLE		UNKNOWN MANHOLE
	ALUMINUM POLE		WATER MANHOLE
	ALUMINUM LIGHT POLE		SEWER MANHOLE
	WOOD POLE		PHONE MANHOLE
	WOOD POWER POLE		IRRIGATION MANHOLE
	WOOD LIGHT POLE		GREASE TRAP MANHOLE
	TRAFFIC BOX		GAS MANHOLE
	STREET LIGHT BOX		FIREMAN MANHOLE
	PHONE BOX		ELECTRICITY MANHOLE
	IRRIGATION BOX		DRAINAGE MANHOLE
	ELECTRIC BOX		COMMUNICATION MANHOLE
	COMMUNICATION BOX		WELL SOUTH MANHOLE
	CABLE T.V. BOX		PARKING METER
	UNKNOWN BOX		PARKING HOOK
	TRAFFIC CONTROL BOX		WATER VALVE
	CLEANOUT		SEWER VALVE
	BOLLARD		IRRIGATION VALVE
	ARM GATE		GAS VALVE
	CHECK VALVE		FORCE MAIN VALVE
	WATER METER		INFLOW BREAKER ASSEMBLY
	IRRIGATION METER		SAMESE CONNECTION
	GAS METER		POST INDICATOR VALVE
	ELECTRIC METER		FIRE HYDRANT
	SQUARE COLUMN		DOUBLE DETECTOR CHECK VALVE
	ROUND COLUMN		PROPERTY LINE
	MAIL BOX		CENTERLINE
	IRRIGATION PUMP		RIGHT-OF-WAY
	GUARD POST		RADIUS
	FLAG POLE		ARC DISTANCE
	DRAINAGE WELL		PERMANENT CONTROL POINT
	SQUARE DRAINAGE		PERMANENT REFERENCE MONUMENT
	PS INLET		FLAT BOOK AND PAGE
	PS INLET		OVERHEAD UTILITY WIRES
	PS INLET		OFFICIAL RECORDS BOOK
	PS INLET		CONCRETE BLOCK STRUCTURE
	PS INLET		CONCRETE
	PS INLET		CHAINLINK FENCE
	PS INLET		WOOD FENCE
	PS INLET		FOUND IRON PIPE
	PS INLET		FOUND NAIL & BRASS DISC
	PS INLET		CLEAR
	PS INLET		ENCROACHMENT
	PS INLET		SEED OR LEGAL DISTANCE
	PS INLET		MEASURED DISTANCE
	PS INLET		RECORD OR PLATTED DISTANCE
	PS INLET		RECORD CALCULATED
	PS INLET		UTILITY EASEMENT
	PS INLET		CONCRETE
	PS INLET		CONCRETE
	PS INLET		CONCRETE PALM
	PS INLET		DENOTES TREE

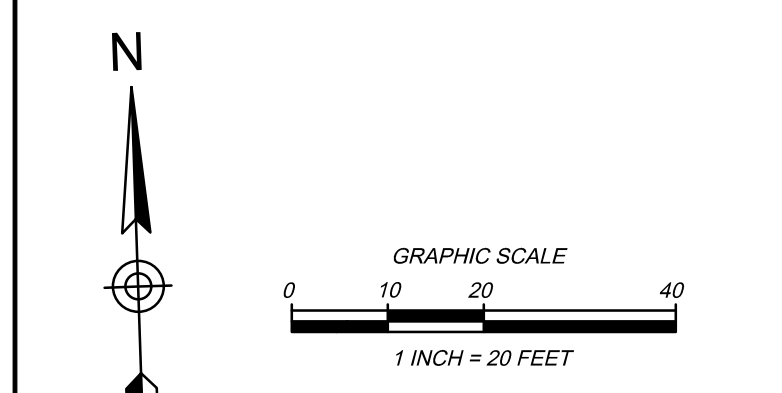

SURVEYOR'S NOTES

- FIELD SURVEY WAS COMPLETED ON: APRIL 29, 2025 AND UPDATED ON SEPTEMBER 22, 2025.
- LEGAL DESCRIPTION WAS PROVIDED BY THE CLIENT.
- SUBJECT PROPERTY AREA: SEARS SITE 965,051 SQ FT (2.202 ACRES); JC PENNY SITE 419,055 SQ FT (9.520 ACRES); PARCEL #1 - JC PENNY SITE 419,055 SQ FT (9.520 ACRES); PARCEL #2 87,507 SQ FT (2.011 ACRES); PARCEL #3 87,507 SQ FT (2.011 ACRES); PARCEL #4 18,000 SQ FT (0.412 ACRES); PARCEL #5 414 SQ FT (0.101 ACRES).
- A PORTION OF PERMANENT ACCESS EASEMENT: 90,340 SQ FT (2.074 ACRES).
- BEARINGS BASED ON AN ASSUMED BEARING OF EAST ALONG THE NORTH LINE OF SUBJECT PROPERTY SITE #1.
- DISTANCES ALONG BOUNDARY LINES, AS SHOWN HEREON, ARE RECORD AND/OR MEASURED UNLESS OTHERWISE NOTED.
- INTERIOR LOT LINES, AS SHOWN HEREON, ARE FOR INFORMATIONAL PURPOSES ONLY UNLESS OTHERWISE NOTED.
- UNDERGROUND FOOTINGS, FOUNDATIONS AND HAVE NOT BEEN LOCATED AT THE TIME OF THIS SURVEY UNLESS OTHERWISE NOTED.
- ABOVEGROUND AND/OR VISIBLE UTILITIES HAVE BEEN LOCATED AT THE TIME OF THIS SURVEY UNLESS OTHERWISE NOTED.
- SUBJECT PROPERTY HAS A CORRECT PHYSICAL ACCESS TO AND FROM PERMANENT ACCESS EASEMENT.
- THE SURVEYOR DOES NOT DETERMINE FENCE AND/OR WALL OWNERSHIP.
- THERE IS A GAP BETWEEN SEARS SITE AND PERMANENT ACCESS EASEMENT.
- THIS BOUNDARY SURVEY IS SUBJECT TO EASEMENTS, RIGHTS-OF-WAY AND OTHER MATTERS THAT MIGHT BE REFLECTED ON A SEARCH OF TITLE OF THE SUBJECT PROPERTY.

PROPERTY INFORMATION

- SEARS SITE**
- PROPERTY ADDRESS: 1625 NW 107th AVE
 - CITY OF DORAL, MIAMI-DADE, FL 33172
 - PARCEL ID: 35-3032-008-050
- JC PENNY SITE**
- PROPERTY ADDRESS: 1603 NW 107th AVE
 - CITY OF DORAL, MIAMI-DADE, FL 33172
 - PARCEL ID: 35-3032-008-040

CERTIFY TO:

- GREYSTAR DEVELOPMENT EAST, LLC, A DELAWARE LIMITED LIABILITY COMPANY.
- FIRST AMERICAN TITLE INSURANCE COMPANY
- GREENBERG TRAURIG, PA

POSSIBLE ENCROACHMENTS

- PARCEL K3 - POSSIBLE ENCROACHMENTS
- A PORTION OF CHAIN LINK FENCE, ALONG THE EAST BOUNDARY LINE, ENCRACH 0.7' FROM ADJOINING LAND ONTO SUBJECT PROPERTY. (SEE PAGE 13)
- A PORTION OF TEMPORARY CHAIN LINK FENCE, ALONG THE SOUTHWESTERLY BOUNDARY LINE, ENCRACH 1.7' FROM SUBJECT PROPERTY ONTO PERMANENT ACCESS EASEMENT. (SEE PAGE 13)

REVISIONS

DATE	JOB No.	REV.	BY.
05/27/25	155116	UPDATE TITLE OF COMMITMENT	C.A.F.
09/23/25	155443-S	UPDATE BOUNDARY SURVEY	C.A.F.
06/11/25	155443-S	UPDATE BOUNDARY SURVEY	C.A.F.

BOUNDARY SURVEY

FIELD SURVEY WAS COMPLETED ON: APRIL 29, 2025 AND UPDATED ON SEPTEMBER 23, 2025.

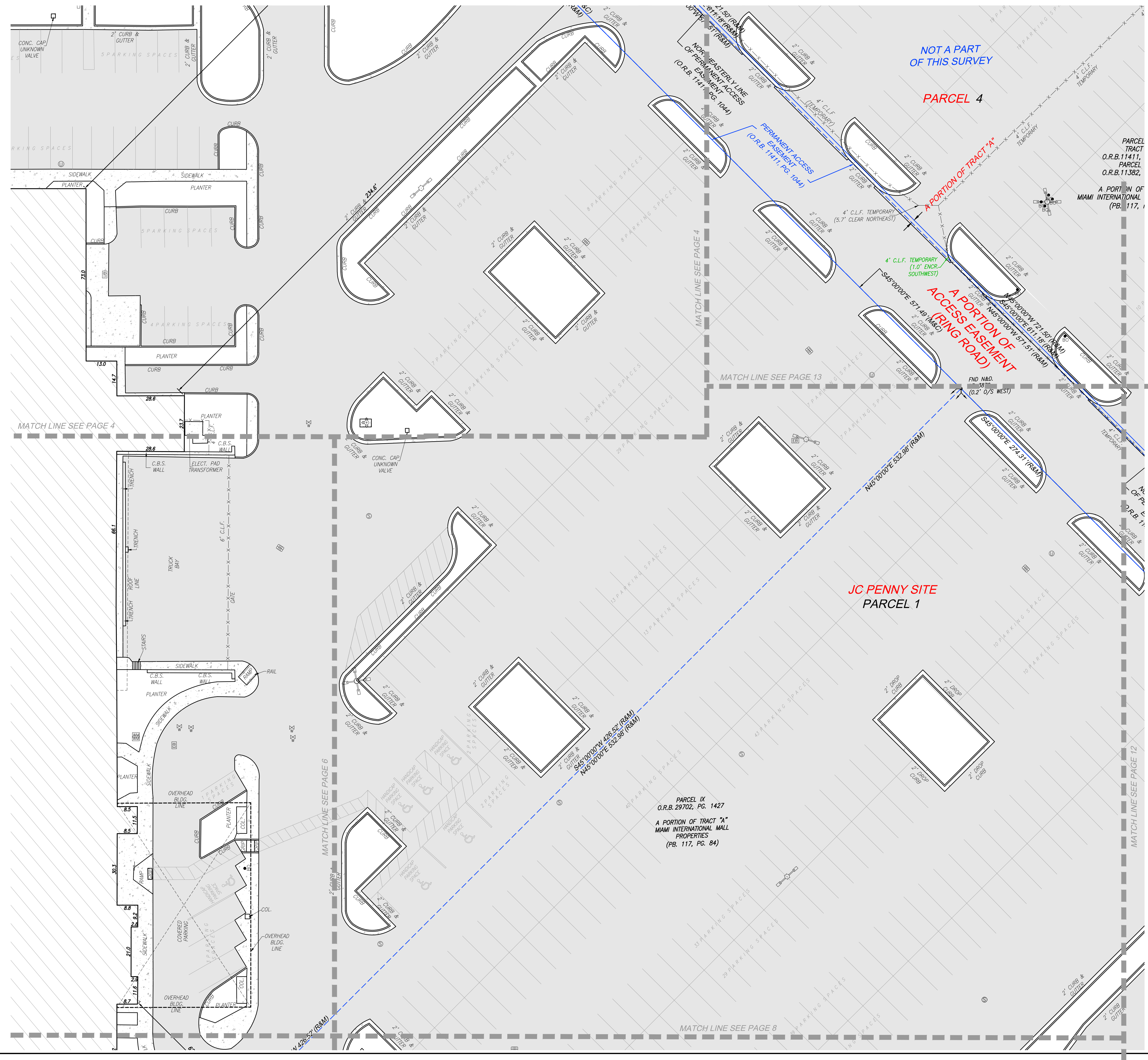

BOUNDARY SURVEY

PREPARED FOR:
GREYSTAR DEVELOPMENT EAST, LLC
LYING AND BEING IN SECTION 32, TOWNSHIP 53 SOUTH, RANGE 40 EAST
CITY OF DORAL, MIAMI-DADE COUNTY, FLORIDA.

J. Hernandez & Associates Inc
LAND SURVEYORS AND MAPPERS
CERTIFICATE OF AUTHORIZATION NO. LB8092
33000 NW 112th AVE, SUITE #10, DORAL, FL 33172
(P) 305-526-0066 (E) info@jhsurveyors.com

DRAWN BY: C.A.F. CHECKED BY: J.G.H. JOB NUM: 155116
DATE: 05/01/2025 DATE: 05/01/2025 F.B. NO: MD-90, PG. 30

LEGAL DESCRIPTION

SEARS SITE

A PORTION OF A PARCEL LOCATED WITHIN SECTION 32, TOWNSHIP 53 SOUTH, RANGE 40 EAST, CITY OF DORAL, MIAMI-DADE COUNTY, FLORIDA, AND FURTHER BOUNDED AND DESCRIBED AS FOLLOWS:

BEGINNING AT A PIPE IN CONCRETE MARKING THE SOUTHWEST CORNER OF SAID SECTION 32, TOWNSHIP 53 SOUTH, RANGE 40 EAST, BEARING N 87° 20' 00" E ALONG THE WEST LINE OF SAID SECTION 32 A DISTANCE OF 304.15 FEET TO A POINT; THENCE S 87° 20' 00" E A DISTANCE OF 1717.80 FEET TO A POINT; THENCE N 87° 20' 00" E A DISTANCE OF 1717.80 FEET TO A POINT; THENCE N 00° 21' 00" W A DISTANCE OF 1320 FEET TO THE POINT OF BEGINNING.

PARCEL 4

A PORTION OF TRACT 2A, MIAMI INTERNATIONAL MALL PROPERTIES, ACCORDING TO THE PLAT THEREOF AS RECORDED IN PLAT BOOK 117, PAGE 84, OF THE PUBLIC RECORDS OF MIAMI-DADE COUNTY, AND BEING MORE PARTICULARLY DESCRIBED AS FOLLOWS:

BEGINNING AT A PIPE IN CONCRETE MARKING THE SOUTHWEST CORNER OF SAID SECTION 32, TOWNSHIP 53 SOUTH, RANGE 40 EAST, BEARING N 87° 20' 00" E ALONG THE WEST LINE OF SAID SECTION 32 A DISTANCE OF 304.15 FEET TO A POINT; THENCE S 87° 20' 00" E A DISTANCE OF 1717.80 FEET TO A POINT; THENCE N 87° 20' 00" E A DISTANCE OF 1717.80 FEET TO A POINT; THENCE N 00° 21' 00" W A DISTANCE OF 1320 FEET TO THE POINT OF BEGINNING.

PARCEL 1

A PORTION OF TRACT 2A, MIAMI INTERNATIONAL MALL PROPERTIES, ACCORDING TO THE PLAT THEREOF AS RECORDED IN PLAT BOOK 117, PAGE 84, OF THE PUBLIC RECORDS OF MIAMI-DADE COUNTY, AND BEING MORE PARTICULARLY DESCRIBED AS FOLLOWS:

BEGINNING AT A PIPE IN CONCRETE MARKING THE SOUTHWEST CORNER OF SAID SECTION 32, TOWNSHIP 53 SOUTH, RANGE 40 EAST, BEARING N 87° 20' 00" E ALONG THE WEST LINE OF SAID SECTION 32 A DISTANCE OF 304.15 FEET TO A POINT; THENCE S 87° 20' 00" E A DISTANCE OF 1717.80 FEET TO A POINT; THENCE N 87° 20' 00" E A DISTANCE OF 1717.80 FEET TO A POINT; THENCE N 00° 21' 00" W A DISTANCE OF 1320 FEET TO THE POINT OF BEGINNING.

PARCEL IX

A PORTION OF TRACT 2A, MIAMI INTERNATIONAL MALL PROPERTIES, ACCORDING TO THE PLAT THEREOF AS RECORDED IN PLAT BOOK 117, PAGE 84, OF THE PUBLIC RECORDS OF MIAMI-DADE COUNTY, AND BEING MORE PARTICULARLY DESCRIBED AS FOLLOWS:

BEGINNING AT A PIPE IN CONCRETE MARKING THE SOUTHWEST CORNER OF SAID SECTION 32, TOWNSHIP 53 SOUTH, RANGE 40 EAST, BEARING N 87° 20' 00" E ALONG THE WEST LINE OF SAID SECTION 32 A DISTANCE OF 304.15 FEET TO A POINT; THENCE S 87° 20' 00" E A DISTANCE OF 1717.80 FEET TO A POINT; THENCE N 87° 20' 00" E A DISTANCE OF 1717.80 FEET TO A POINT; THENCE N 00° 21' 00" W A DISTANCE OF 1320 FEET TO THE POINT OF BEGINNING.

SURVEYOR'S CERTIFICATION:

I HEREBY CERTIFY THAT THIS "BOUNDARY SURVEY" OF THE PROPERTY DESCRIBED HEREON IS TRUE AND CORRECT TO THE BEST OF MY KNOWLEDGE AND BELIEF AS RECENTLY SURVEYED AND DRAWN UNDER MY SUPERVISION AND DIRECTION. THIS SURVEY COMPLIES WITH STANDARDS OF PRACTICE REQUIREMENTS ADOPTED BY THE FLORIDA STATE BOARD OF SURVEYORS AND MAPPERS, PURSUANT TO CHAPTER 35-17, FLORIDA ADMINISTRATIVE CODE.

THIS CERTIFICATION DOES NOT EXTEND TO ANY UNNAMED PARTIES.

BY:

JOSE G. HERNANDEZ, PRESIDENT
PROFESSIONAL LAND SURVEYOR NO. 8952
STATE OF FLORIDA

THE ELECTRONIC SEAL AND SIGNATURE APPEARING ON THIS SURVEY WAS AUTHORIZED BY JOSE G. HERNANDEZ, PROFESSIONAL LAND SURVEYOR NO. 8952 OF THE STATE OF FLORIDA ON MARCH 24, 2025.

THIS IS A BOUNDARY SURVEY
PROJECT NUMBER: MD-730
SHEET NUMBER: 7 OF 13

BOUNDARY SURVEY

FIELD SURVEY WAS COMPLETED ON: APRIL 29, 2025 AND UPDATED ON SEPTEMBER 23, 2025.

BOUNDARY SURVEY

PREPARED FOR: GREYSTAR DEVELOPMENT EAST, LLC LYING AND BEING IN SECTION 32, TOWNSHIP 53 SOUTH, RANGE 40 EAST CITY OF DORAL, MIAMI-DADE COUNTY, FLORIDA.

J. Hernandez & Associates Inc. LAND SURVEYORS AND MAPPERS CERTIFICATE OF AUTHORIZATION No. LB8092 3300 NW 17th Avenue, Suite #10, Doral, FL 33172 (P) 305-526-0006 (E) jh@jhsurveyors.com

DRAWN BY: J.G.H. CHECKED BY: J.G.H. JOB NO. 155116 DATE: 05/01/2025 DATE: 05/01/2025 F.B. MD-80, PG. 30

LEGAL DESCRIPTION

PARCEL #1: A PORTION OF TRACT "A" MIAMI INTERNATIONAL MALL PROPERTIES ACCORDING TO THE PLAT THEREOF AS RECORDED IN PLAT BOOK 117, PAGE 86, OF THE PUBLIC RECORDS OF MIAMI-DADE COUNTY, FLORIDA...

PARCEL #2: EASEMENT RIGHTS AS SET FORTH IN THE MIAMI INTERNATIONAL MALL EASEMENT AND OPERATING AGREEMENT BY AND AMONG SEARS, ROEBUCK AND CO., ALSTORS REALTY CORPORATION, JORDAN MASHAM COMPANY, REGISTERED DEVELOPERS...

PARCEL #3: A PORTION OF TRACT "A" MIAMI INTERNATIONAL MALL PROPERTIES ACCORDING TO THE PLAT THEREOF AS RECORDED IN PLAT BOOK 117, PAGE 86, OF THE PUBLIC RECORDS OF MIAMI-DADE COUNTY, AND BEING MORE PARTICULARLY DESCRIBED AS FOLLOWS...

PARCEL #4: A PORTION OF TRACT "A" MIAMI INTERNATIONAL MALL PROPERTIES ACCORDING TO THE PLAT THEREOF AS RECORDED IN PLAT BOOK 117, PAGE 86, OF THE PUBLIC RECORDS OF MIAMI-DADE COUNTY, AND BEING MORE PARTICULARLY DESCRIBED AS FOLLOWS...

PARCEL #5: A PORTION OF TRACT "A" MIAMI INTERNATIONAL MALL PROPERTIES ACCORDING TO THE PLAT THEREOF AS RECORDED IN PLAT BOOK 117, PAGE 86, OF THE PUBLIC RECORDS OF MIAMI-DADE COUNTY, AND BEING MORE PARTICULARLY DESCRIBED AS FOLLOWS...

PARCEL #6: A PORTION OF TRACT "A" MIAMI INTERNATIONAL MALL PROPERTIES ACCORDING TO THE PLAT THEREOF AS RECORDED IN PLAT BOOK 117, PAGE 86, OF THE PUBLIC RECORDS OF MIAMI-DADE COUNTY, AND BEING MORE PARTICULARLY DESCRIBED AS FOLLOWS...

PARCEL #7: A PORTION OF TRACT "A" MIAMI INTERNATIONAL MALL PROPERTIES ACCORDING TO THE PLAT THEREOF AS RECORDED IN PLAT BOOK 117, PAGE 86, OF THE PUBLIC RECORDS OF MIAMI-DADE COUNTY, AND BEING MORE PARTICULARLY DESCRIBED AS FOLLOWS...

PARCEL #8: A PORTION OF TRACT "A" MIAMI INTERNATIONAL MALL PROPERTIES ACCORDING TO THE PLAT THEREOF AS RECORDED IN PLAT BOOK 117, PAGE 86, OF THE PUBLIC RECORDS OF MIAMI-DADE COUNTY, AND BEING MORE PARTICULARLY DESCRIBED AS FOLLOWS...

PARCEL #9: A PORTION OF TRACT "A" MIAMI INTERNATIONAL MALL PROPERTIES ACCORDING TO THE PLAT THEREOF AS RECORDED IN PLAT BOOK 117, PAGE 86, OF THE PUBLIC RECORDS OF MIAMI-DADE COUNTY, AND BEING MORE PARTICULARLY DESCRIBED AS FOLLOWS...

PARCEL #10: A PORTION OF TRACT "A" MIAMI INTERNATIONAL MALL PROPERTIES ACCORDING TO THE PLAT THEREOF AS RECORDED IN PLAT BOOK 117, PAGE 86, OF THE PUBLIC RECORDS OF MIAMI-DADE COUNTY, AND BEING MORE PARTICULARLY DESCRIBED AS FOLLOWS...

THIS IS A BOUNDARY SURVEY PROJECT NUMBER: MD-730 SHEET NUMBER: 8 OF 13

LEGEND AND ABBREVIATIONS: CONCRETE POLE, CONCRETE POWER POLE, ALUMINUM POLE, WOOD POLE, TRAFFIC BOX, STREET LIGHT BOX, PHONE BOX, IRRIGATION BOX, ELECTRIC BOX, CABLE TV BOX, UNKNOWN BOX, TRAFFIC CONTROL BOX, CLEANOUT, BOLLARD, ARM GATE, ARCH, WATER METER, IRRIGATION METER, GAS METER, ELECTRIC METER, SQUARE COLUMN, ROUND COLUMN, MAIL BOX, IRRIGATION PUMP, GUARD POST, FLAG POLE, DRAINAGE WELL, SQUARE DRAINAGE, PB INLET, CURB INLET, CIRCULAR DRAINAGE, CATCH BASIN, ACCESS MANHOLE, SMALLE INLET, TRAFFIC SIGNAL POLE, SURVEILLANCE CAMERA, PEDESTRIAN CROSS SIGNAL, PAVEMENT ASPHALT, HANDICAP PAINT MARK, BABY STROLLER PAINT MARK, UNKNOWN MANHOLE, WATER MANHOLE, SEWER MANHOLE, PHONE MANHOLE, IRRIGATION MANHOLE, GREASE TRAP MANHOLE, GAS MANHOLE, FORCEMAIN MANHOLE, ELECTRICITY MANHOLE, COMMUNICATION MANHOLE, HOLE SOUTH MANHOLE, PARKING METER, PARKING KIOSK, WATER VALVE, SEWER VALVE, GAS VALVE, FORCE MAIN VALVE, UNKNOWN BREAKER ASSEMBLY, SHIMASE CONNECTION, POST INDICATOR VALVE, FIRE HYDRANT, DOUBLE DETECTOR CHECK VALVE, BACK FLOW PREVENTOR, CENTRING, RIGHT-OF-WAY, RADIUS, ARC DISTANCE, PERMANENT CONTROL POINT, PERMANENT SURVEY MONUMENT, FLAT BOOK AND PAGE, OVERHEAD UTILITY WIRES, OFFICIAL RECORDS BOOK, CONCRETE BLOCK STRUCTURE, CHAINLINK FENCE, WOOD FENCE, FOUND IRON PIPE, FOUND WIRE & BRASS DISC, CLEAR ENCRUSHMENT, DEED OR LEGAL DISTANCE, MEASURED DISTANCE, RECORD OR PLATTED DISTANCE, RECORD CALCULATED, UTILITY EASEMENT, CONCRETE, DENOTES PALM, DENOTES TREE

GRAPHIC SCALE: 1 INCH = 20 FEET. Includes a north arrow and a scale bar from 0 to 40 feet.

SURVEYOR'S NOTES: 1. FIELD SURVEY WAS COMPLETED ON: APRIL 29, 2025 AND UPDATED ON SEPTEMBER 23, 2025. 2. LEGAL DESCRIPTION WAS PROVIDED BY THE CLIENT. 3. SUBJECT PROPERTY AREA: SEARS SITE (0.9551 SQ. FT. (0.022 ACRES))...

PROPERTY INFORMATION: SEARS SITE: PROPERTY ADDRESS: 1625 NW 107th AVE, CITY OF DORAL, MIAMI-DADE, FL 33172. JC PENNY SITE: PROPERTY ADDRESS: 1603 NW 107th AVE, CITY OF DORAL, MIAMI-DADE, FL 33172.

CERTIFY TO: GREYSTAR DEVELOPMENT EAST, LLC, A DELAWARE LIMITED LIABILITY COMPANY. FIRST AMERICAN TITLE INSURANCE COMPANY. GREENBERG TRAURIG, PA.

POSSIBLE ENCROACHMENTS: A PORTION OF CHAIN LINK FENCE, ALONG THE WEST BOUNDARY LINE, ENDOACH 0.7' FROM SUBJECT PROPERTY ONTO ADJOINING LAND. A PORTION OF TEMPORARY CHAIN LINK FENCE, ALONG THE NORTHEASTERLY BOUNDARY LINE, ENDOACH 1.7' FROM SUBJECT PROPERTY ONTO PERMANENT ACCESS EASEMENT.

REVISIONS table with columns: DATE, JOB No., REV., UPDATE TITLE OF COMMENT, C.A.F.

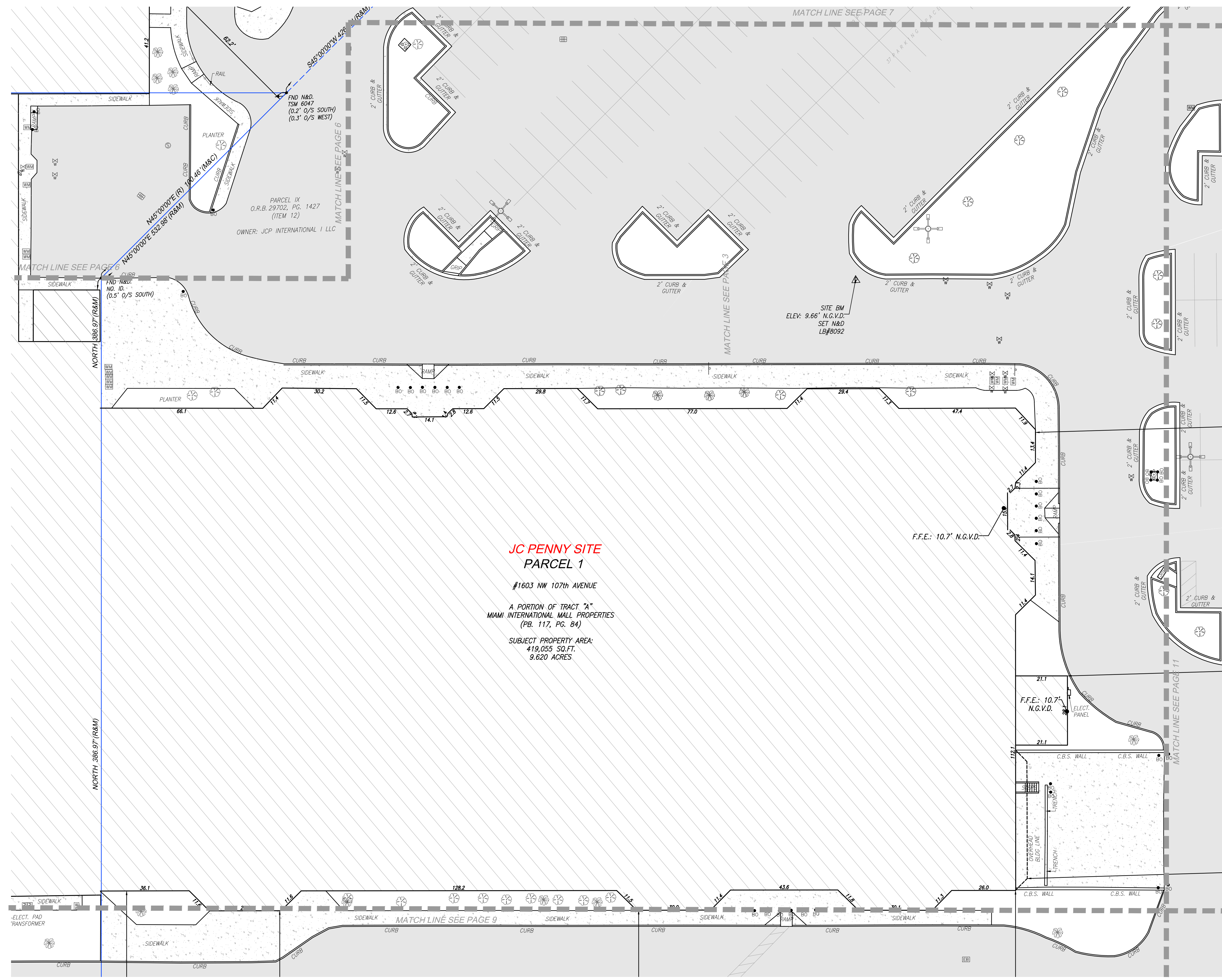

JC PENNY SITE PARCEL 1 #1603 NW 107th AVENUE A PORTION OF TRACT "A" MIAMI INTERNATIONAL MALL PROPERTIES (PB. 117, PG. 84) SUBJECT PROPERTY AREA: 419,055 SQ.FT. 9.620 ACRES

SURVEYOR'S CERTIFICATION: I HEREBY CERTIFY THAT THIS "BOUNDARY SURVEY" OF THE PROPERTY DESCRIBED HEREON IS TRUE AND CORRECT TO THE BEST OF MY KNOWLEDGE AND BELIEF AS RECENTLY SURVEYED AND DRAWN UNDER MY SUPERVISION AND DIRECTION. THIS SURVEY COMPLIES WITH STANDARDS OF PRACTICE REQUIREMENTS ADOPTED BY THE FLORIDA STATE BOARD OF SURVEYORS AND MAPPERS, PURSUANT TO CHAPTER 35-17, FLORIDA ADMINISTRATIVE CODE.

THIS CERTIFICATION DOES NOT EXTEND TO ANY UNNAMED PARTIES. BY: JOSE G. HERNANDEZ, PRESIDENT PROFESSIONAL LAND SURVEYOR No. 8952 STATE OF FLORIDA.

THE ELECTRONIC SEAL AND SIGNATURE APPEARING ON THIS SURVEY WAS AUTHORIZED BY JOSE G. HERNANDEZ, PROFESSIONAL LAND SURVEYOR NO. 8952 OF THE STATE OF FLORIDA ON MARCH 24, 2025.

BOUNDARY SURVEY

FIELD SURVEY WAS COMPLETED ON: APRIL 29, 2025 AND UPDATED ON SEPTEMBER 23, 2025.

BOUNDARY SURVEY

PREPARED FOR: GREYSTAR DEVELOPMENT EAST, LLC LYING AND BEING IN SECTION 32, TOWNSHIP 53 SOUTH, RANGE 40 EAST CITY OF DORAL, MIAMI-DADE COUNTY, FLORIDA.

J. Hernandez & Associates Inc LAND SURVEYORS AND MAPPERS CERTIFICATE OF AUTHORIZATION No. LB8092 3300 NW 12th AVE, SUITE #10, DORAL, FL 33172 (P) 305-526-0808 (E) info@hsurveys.com

DRAWN BY: J.G.H. CHECKED BY: J.G.H. JOB NUM: 155116 DATE: 05/01/2025 DATE: 05/01/2025 F.B. MD-90, PG. 30

LEGAL DESCRIPTION

PARCEL #1: A PARCEL OF LAND LOCATED WITHIN SECTION 32, TOWNSHIP 53 SOUTH, RANGE 40 EAST, CITY OF DORAL, MIAMI-DADE COUNTY, FLORIDA AND FURTHER BOUNDARIES AND DESCRIBED AS FOLLOWS: BEGINNING AT A PIPE IN CONCRETE MARKING THE SOUTHWEST CORNER OF SAID SECTION 32...

LEGEND AND ABBREVIATIONS table listing symbols for various utility features like concrete poles, manholes, valves, and fences.

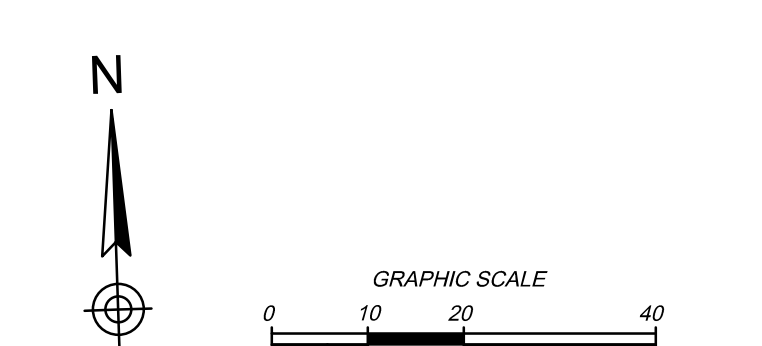

SURVEYOR'S NOTES: 1. FIELD SURVEY WAS COMPLETED ON: APRIL 29, 2025 AND UPDATED ON SEPTEMBER 23, 2025.

PROPERTY INFORMATION: SEARS SITE - PROPERTY ADDRESS: 1625 NW 107th AVE, CITY OF DORAL, MIAMI-DADE, FL 33172. JC PENNY SITE - PROPERTY ADDRESS: 1633 NW 107th AVE, CITY OF DORAL, MIAMI-DADE, FL 33172.

CERTIFY TO: GREYSTAR DEVELOPMENT EAST, LLC, A DELAWARE LIMITED LIABILITY COMPANY. FIRST AMERICAN TITLE INSURANCE COMPANY. GREENBERG TRAURIG, PA.

POSSIBLE ENCROACHMENTS: PARCEL K3 - POSSIBLE ENCROACHMENTS. A PORTION OF CHAIN LINK FENCE, ALONG THE EAST BOUNDARY LINE, ENCRACH 0.7' FROM ADJOINING LAND ONTO SUBJECT PROPERTY.

REVISIONS table with columns for DATE, JOB No., REV., UPDATE TITLE OF COMMITMENT, and BY.

Table with columns for DATE, JOB No., REV., UPDATE TITLE OF COMMITMENT, and BY.

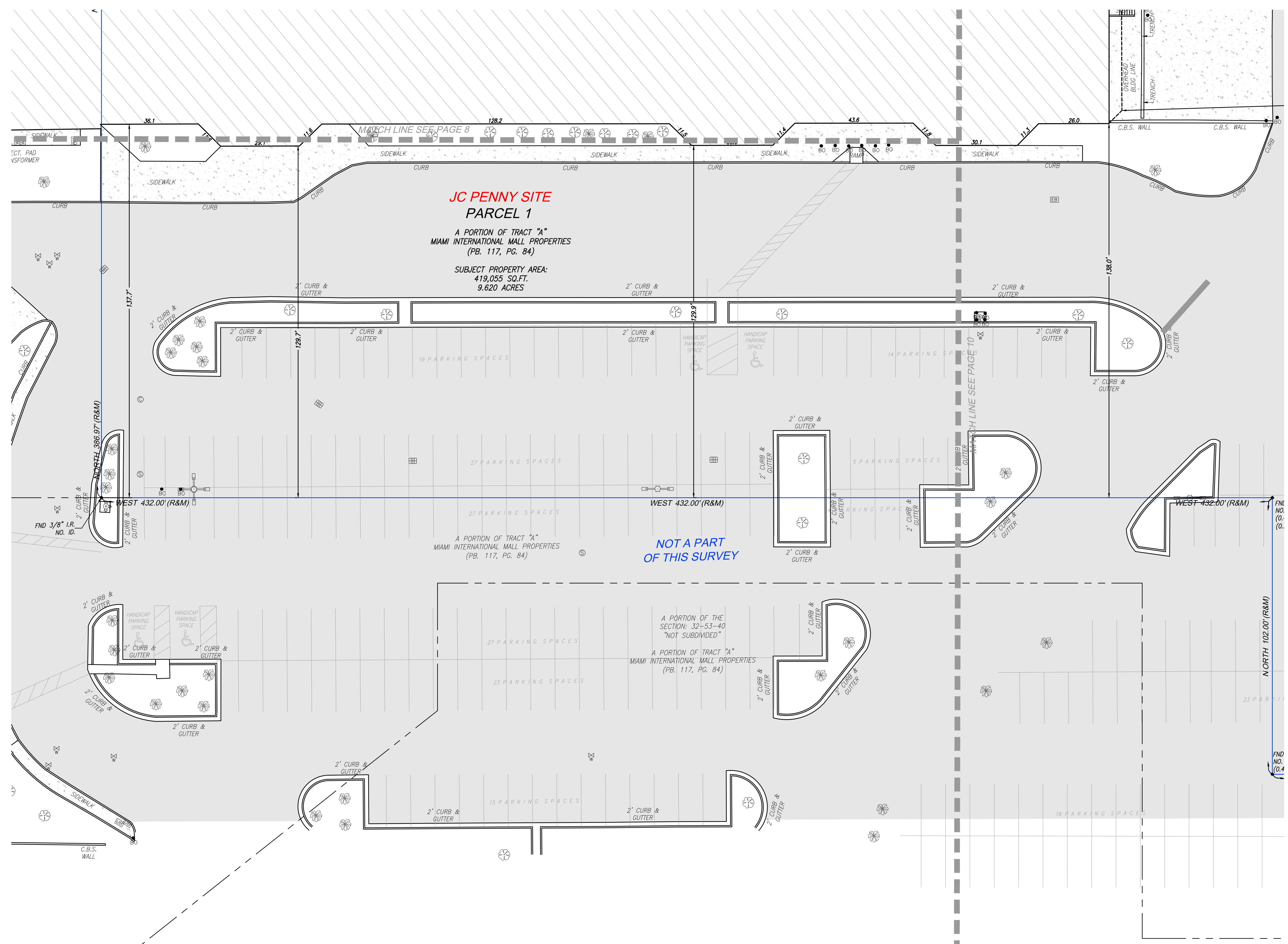

SURVEYOR'S CERTIFICATION: I HEREBY CERTIFY THAT THIS "BOUNDARY SURVEY" OF THE PROPERTY DESCRIBED HEREON IS TRUE AND CORRECT TO THE BEST OF MY KNOWLEDGE AND BELIEF AS RECENTLY SURVEYED AND DRAWN UNDER MY SUPERVISION AND DIRECTION.

THIS CERTIFICATION DOES NOT EXTEND TO ANY UNNAMED PARTIES. BY: JOSE G. HERNANDEZ, PRESIDENT, PROFESSIONAL LAND SURVEYOR No. 8952, STATE OF FLORIDA.

THE ELECTRONIC SEAL AND SIGNATURE APPEARING ON THIS SURVEY WAS AUTHORIZED BY JOSE G. HERNANDEZ, PROFESSIONAL LAND SURVEYOR NO. 8952 OF THE STATE OF FLORIDA ON MARCH 24, 2025.

THIS IS A BOUNDARY SURVEY PROJECT NUMBER: MD-730 SHEET NUMBER: 9 OF 13

BOUNDARY SURVEY

FIELD SURVEY WAS COMPLETED ON: APRIL 29, 2025 AND UPDATED ON SEPTEMBER 23, 2025.

LEGEND AND ABBREVIATIONS table listing symbols for various utility lines, structures, and markers.

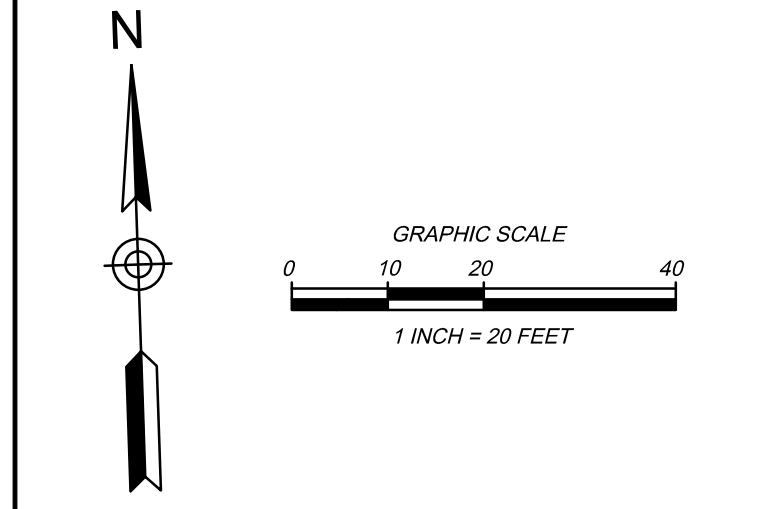

SURVEYOR'S NOTES: 1. FIELD SURVEY WAS COMPLETED ON: APRIL 29, 2025 AND UPDATED ON SEPTEMBER 23, 2025. 2. LEGAL DESCRIPTION WAS PROVIDED BY THE CLIENT...

PROPERTY INFORMATION: SEARS SITE - PROPERTY ADDRESS: 1625 NW 107th AVE, CITY OF DORAL, MIAMI-DADE, FL 33172. JC PENNY SITE - PROPERTY ADDRESS: 1603 NW 107th AVE, CITY OF DORAL, MIAMI-DADE, FL 33172.

CERTIFY TO: GREYSTAR DEVELOPMENT EAST, LLC, A DELAWARE LIMITED LIABILITY COMPANY. FIRST AMERICAN TITLE INSURANCE COMPANY. GREENBERG TRAURIG, PA.

POSSIBLE ENCROACHMENTS: PARCEL K3 - POSSIBLE ENCROACHMENTS. A PORTION OF CHAIN LINK FENCE, ALONG THE EAST BOUNDARY LINE, ENDOACH 0.7' FROM ADJOINING LAND ONTO SUBJECT PROPERTY.

REVISIONS table with columns for DATE, JOB No., REV., UPDATE TITLE OF COMMITMENT, and BY.

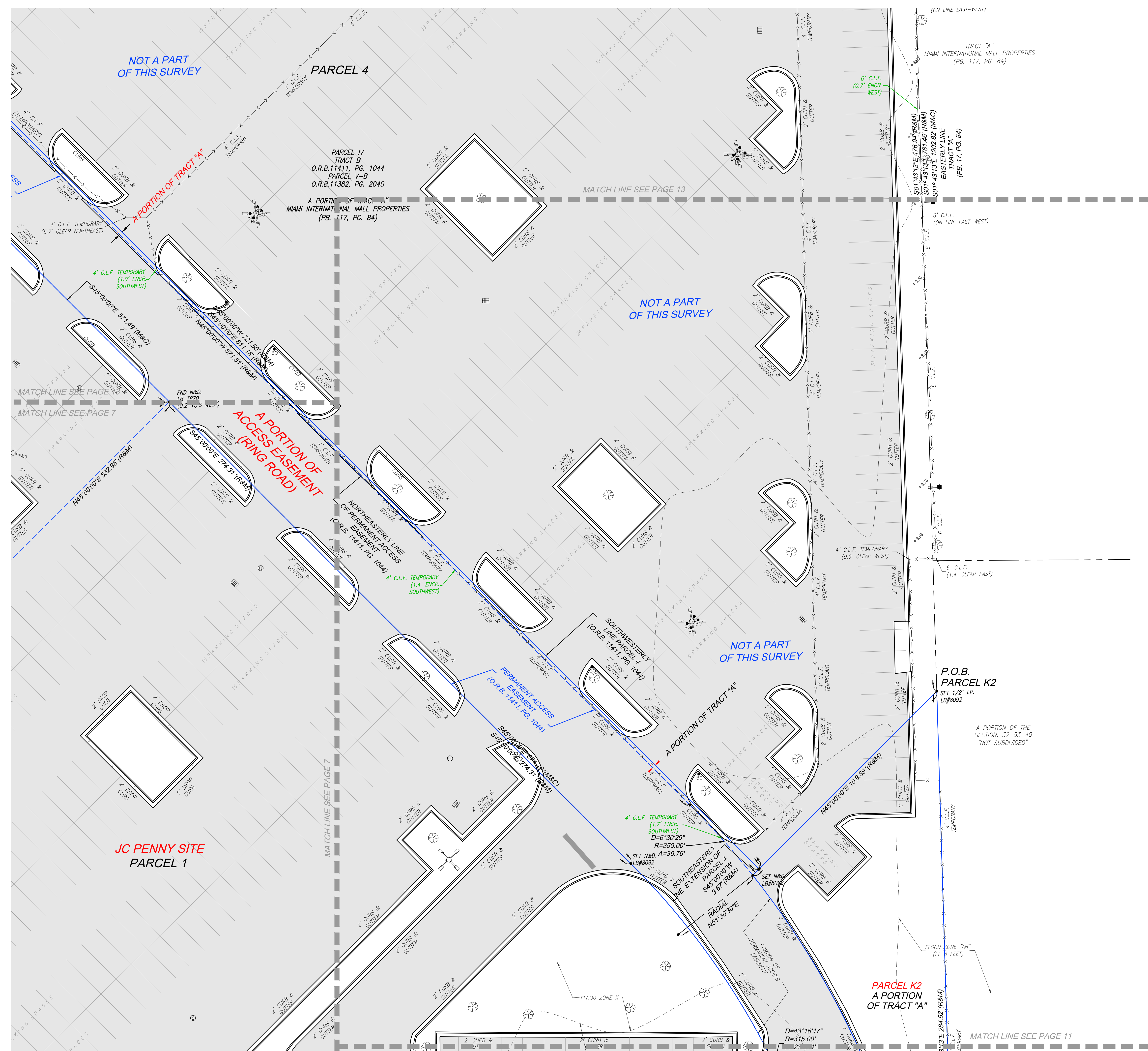

BOUNDARY SURVEY PREPARED FOR: GREYSTAR DEVELOPMENT EAST, LLC. J. Hernandez & Associates Inc. LAND SURVEYORS AND MAPPERS. CERTIFICATE OF AUTHORIZATION No. LB8092.

LEGAL DESCRIPTION: A PORTION OF LAND LOCATED WITHIN SECTION 32, TOWNSHIP 33 SOUTH, RANGE 40 EAST, AND BEING IN SECTION 32, TOWNSHIP 33 SOUTH, RANGE 40 EAST, CITY OF DORAL, MIAMI-DADE COUNTY, FLORIDA.

PARCEL #1: A PORTION OF TRACT "A" MIAMI INTERNATIONAL MALL PROPERTIES ACCORDING TO THE PLAT THEREOF AS RECORDED IN PLAT BOOK 117, PAGE 84 OF THE PUBLIC RECORDS OF MIAMI-DADE COUNTY, FLORIDA.

PARCEL #2: EASEMENT RIGHTS AS SET FORTH IN THE MIAMI INTERNATIONAL MALL EASEMENT AND OPERATING AGREEMENT BY AND BETWEEN SEARS, ROEBUCK AND CO. ALTORES REALTY CORPORATION, JORDAN MASON COMPANY, REEBERT DEVELOPMENT, INC., AND JORDAN MASON COMPANY.

PARCEL #3: A PORTION OF TRACT "A" MIAMI INTERNATIONAL MALL PROPERTIES ACCORDING TO THE PLAT THEREOF AS RECORDED IN PLAT BOOK 117, PAGE 84 OF THE PUBLIC RECORDS OF MIAMI-DADE COUNTY, FLORIDA.

PARCEL #4: A PORTION OF TRACT "A" MIAMI INTERNATIONAL MALL PROPERTIES ACCORDING TO THE PLAT THEREOF AS RECORDED IN PLAT BOOK 117, PAGE 84 OF THE PUBLIC RECORDS OF MIAMI-DADE COUNTY, FLORIDA.

SURVEYOR'S CERTIFICATION: I HEREBY CERTIFY THAT THIS "BOUNDARY SURVEY" OF THE PROPERTY DESCRIBED HEREON IS TRUE AND CORRECT TO THE BEST OF MY KNOWLEDGE AND BELIEF AS RECENTLY SURVEYED AND DRAWN UNDER MY SUPERVISION AND DIRECTION.

THIS IS A BOUNDARY SURVEY PROJECT NUMBER: MD-730 SHEET NUMBER: 12 OF 13

